

Jamato[®]

INDUSTRIAL SEWING MACHINE

**ILLUSTRATED SPARE PARTS LIST
FOR
SUPER HIGH SPEED
SAFETY STITCH MACHINE**

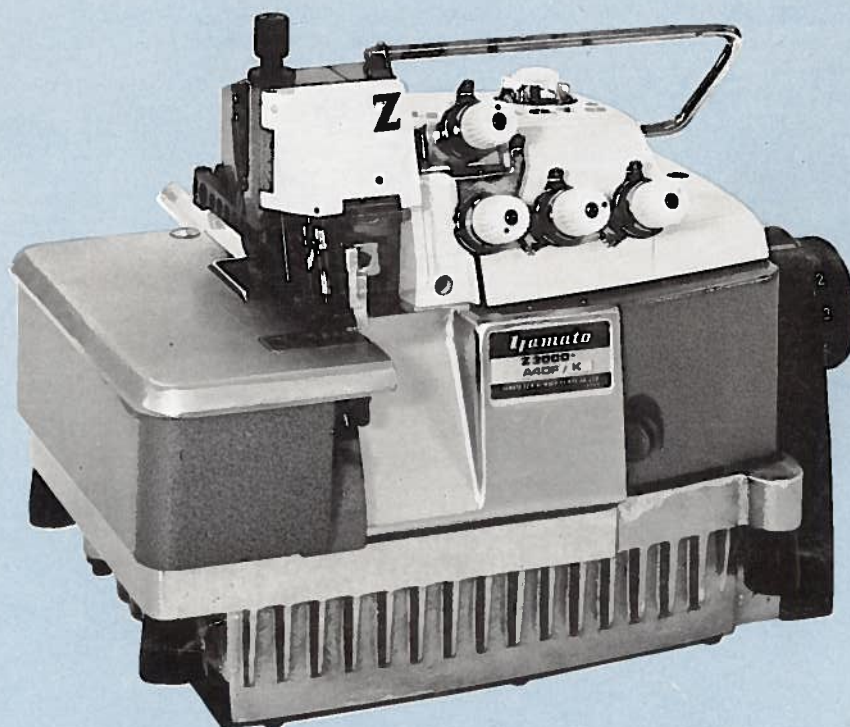

MODELS & DEVICES

Z3000-A Z3002-A

Z3000-C Z3002-C

Z3000-Y Z3002-Y

C2 K MT HR

KONDO SEWING MACHINE CO., LTD.

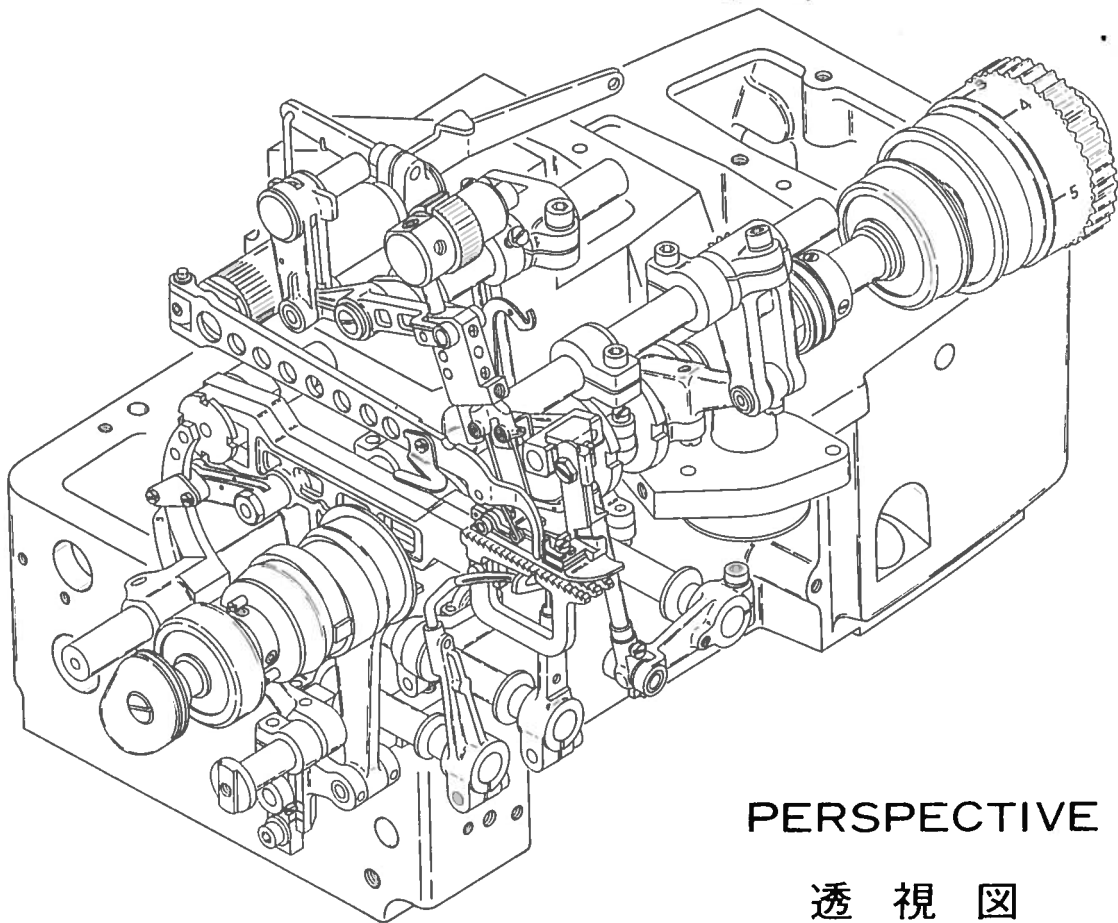

PERSPECTIVE

透視図

CONTENTS

MISCELLANEOUS COVERS (1)	
MISCELLANEOUS COVERS (2)	
MISCELLANEOUS COVERS (3)	
MISCELLANEOUS THREAD EYELETS	
MISCELLANEOUS CRANKSHAFT & BUSHINGS	
NEEDLE DRIVING MECHANISM	
“HR” UNIT	
UPPER KNIFE DRIVING & LOWER KNIFE MECHANISM	
PRESSER FOOT MECHANISM	
UPPER LOOPER DRIVING MECHANISM	
LOWER & DOUBLE CHAINING LOOPER DRIVING MECHANISM	
FEED DRIVING CONTROL MECHANISM	
FEED DRIVING MECHANISM	
LUBRICATING MECHANISM	
Z3000-C, Y & Z3002-A, C, Y EXCLUSIVE PARTS	
“C2” & “K” DEVICE	
“MT” DEVICE	
THREAD STAND & SUPPORTING BOARD	
ACCESSORIES	
LIST OF MAIN SPARE PARTS	
INDEX	

目次

カバー関係(1).....	1
カバー関係(2).....	2
カバー関係(3).....	3
糸道関係.....	4
主軸及びブッシュ関係.....	5
針振り機構.....	6
“HR”装置.....	7
上メス及び下メス機構.....	8
押工機構.....	9
上ルーパ機構.....	10
下ルーパ及び二重環ルーパ機構.....	11
前送り調節機構.....	12
送り機構.....	13
給油機構.....	14
サブクラス専用部品.....	15
“C2”及び“K”装置.....	16
“MT”装置.....	17
糸立台及び受け板.....	18
アクセサリ関係.....	19
主要部品表.....	20
索引.....	21

Illustration of this Parts Book is based on the Model Z3000A.
このパーツブックはZ3000Aを基本にしてイラストを作成しております。

1

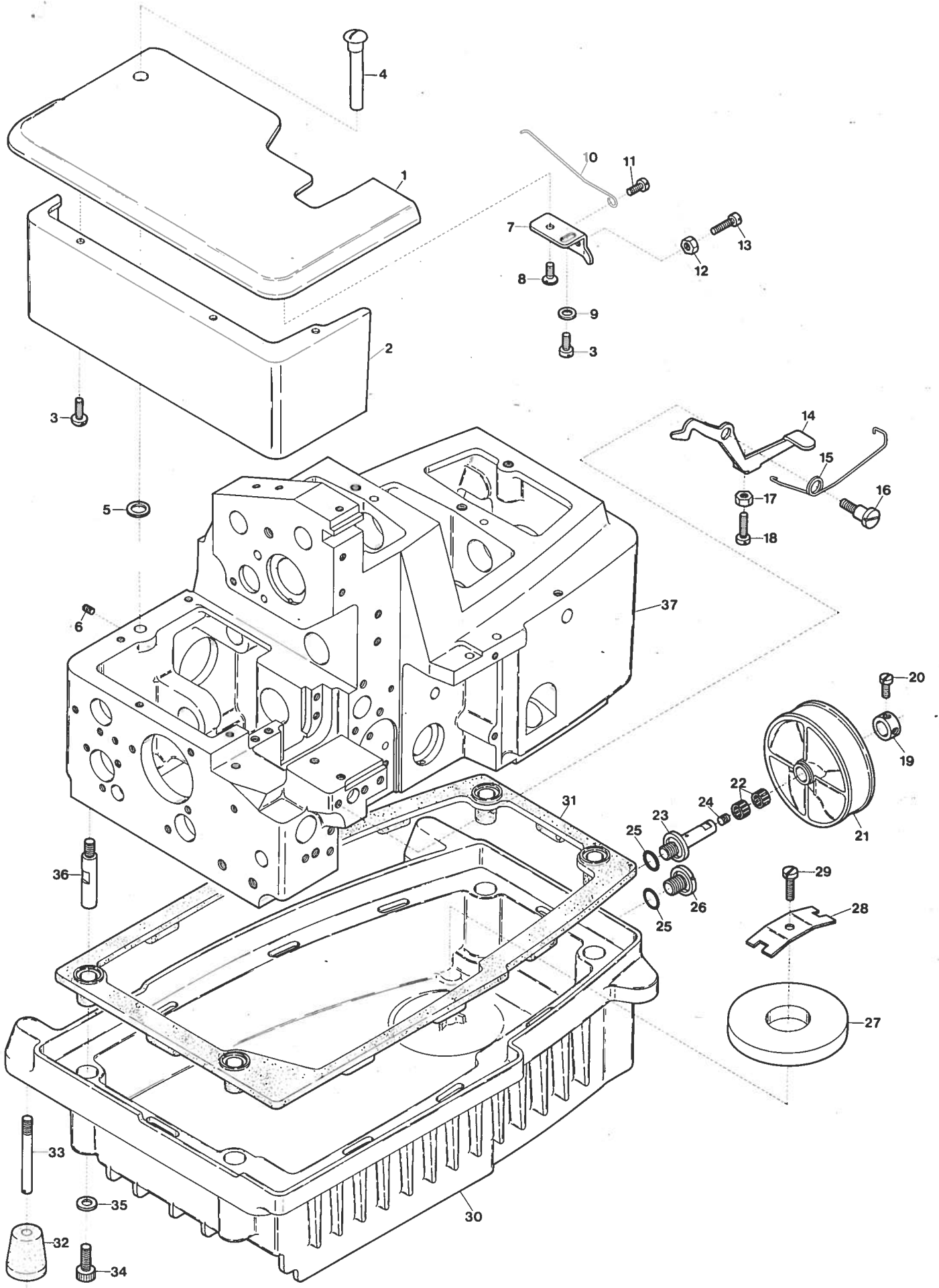

MISCELLANEOUS COVERS(1)

カバー関係(1)

Ref. No.	Parts No.	Description	品名	Amt. Req.
1	20030	Cloth Plate	クロスプレート	1
2	20034	Cloth Plate (Lower)	クロスプレート(下)	1
3	4358	Screw for 20034, 20035	止ネジ	4
4	20032	Cloth Plate Hinge Pin	クロスプレートピン	1
5	20037	Cloth Plate Spacer	クロスプレートスペーサ	1
6	3434	Screw for 20032	クロスプレートピン止ネジ	1
7	20035	Cloth Plate Latch Bracket	クロスプレートラッチ	1
8	9143	Screw for 20035	クロスプレートラッチ止ネジ	1
9	532	Washer for 20035	ワッシャ	1
10	34510	Cloth Plate Spring	クロスプレート戻シバネ	1
11	7006	Screw for 34510	クロスプレート戻シバネ止ネジ	1
12	335	Stopper Nut for 20030	クロスプレートストップナット	1
13	1186	Stopper Screw for 20030	クロスプレートストップバネジ	1
14	20036	Cloth Plate Latch	クロスプレートフック	1
15	20038	Cloth Plate Latch Spring	クロスプレートストップバネ	1
16	4117	Screw for 20036	クロスプレートフック止ネジ	1
17	322	Nut for 20036	クロスプレートフック調節ナット	1
18	1132	Screw for 20036	クロスプレートフック調節ネジ	1
19	30228	Oil Cooling Fan Shaft Collar	ファンシャフトカラー	1
20	9604	Screw for 30228	ファンシャフトカラー止ネジ	2
21	20054	Oil Cooling Fan	ファン	1
22	77366	Roller Bearing	ニードルベアリング	2
23	20056	Oil Cooling Fan Shaft	ファンシャフト	1
24	3646	Screw for 20056	ファンシャフト止ネジ	1
25	32421	O-Ring	Oリング	2
26	5076	Drain Hole Screw	油受ケ油抜キネジ	1
27	35149	Oil Receiver Magnet	油受ケマグネット	1
28	35150	Oil Receiver Magnet Holder	油受ケマグネット押工	1
29	4440	Screw for 35150	油受ケマグネット押工止ネジ	1
30	20048	Oil Receiver	油受ケ	1
31	20049	Oil Receiver Gasket	油受ケパッキン	1
32	20053	Oil Receiver Rubber Cushion	防振ゴム	4
33	6816	Screw for 20053	防振ゴム止ネジ	4
34	5108	Screw for 20048	油受ケ止ネジ	4
35	184	Washer for 20048	ワッシャ	4
36	20050	Oil Receiver Positioning Bar	油受ケ固定棒	4
37	20000	Machine Frame	フレーム	1

Ref. No.	Parts No.	Description	品名	Amt. Req.
1	20105	Thread Lead Bar	糸道棒	1
2	3632	Screw for 20105	糸道棒止ネジ	1
3	20001	Top Cover	上カバー	1
4	5083	Screw for 20001	上カバー止ネジ	2
5	20003	Top Cover Gasket (Right)	上カバーパッキン(右)	1
6	20002	Top Cover Gasket (Left)	上カバーパッキン(左)	1
7	20004	Oil Cap	オイルキャップ	1
8	20005	Oil Cap O-ring	オイルキャップOリング	1
9	20130	Thread Lead Bar Holder	糸道棒振止め	1
10	5345	Screw for 20130	糸道棒振止め止ネジ	2
11	20006	Side Cover	側面カバー	1
12	4122	Screw for 20006	側面カバー止ネジ	1
13	4101	Screw for 20006	側面カバー止ネジ	1
14	20222	Oil Defender	針案内油除ケ	1
15	1196	Screw for 20222	針案内油除ケ止ネジ	1
16	20658	Safety Plate	アイガード	1
17	20659	Safety Plate Hinge Pin	アイガードヒンジピン	1
18	20007	Needle Thread Cover	針糸カバー	1
19	20008	Needle Thread Cover Pin	針糸カバーピン	1
20	976	"Z" Mark	Zマーク	1
21	726	Rivet for 20007	止め鉄	1
22	20660	Safety Plate Latch Spring	アイガードヒンジバネ	1
23	1330	Screw for 20660	アイガードヒンジバネ止ネジ	1
24	20063	Needle Thread Cover Stick Plate	針糸カバー着磁板	1
25	5112	Screw for 20063	針糸カバー着磁板止ネジ	1
26	20067	Needle Thread Cover Magnet, Complete Set	針糸カバーマグネット(組)	1
27	20066	Needle Thread Cover Magnet Case	針糸カバーマグネットケース	1
28	20062	Needle Thread Cover Magnetized Plate	針糸カバー磁化プレート	2
29	20009	Needle Thread Cover Magnet	針糸カバーマグネット	1
30	20065	Cover for 20066	針糸カバーマグネットケース蓋	1
31	9533	Screw for 20067	針糸カバーマグネット(組)止ネジ	1
32	20014	Front Cover Latch Spring	前カバーラッチバネ	1
33	9121	Screw for 20014	前カバーラッチバネ止ネジ	1
34	20024	Dust-Free Cover (Lower)	防塵カバー(下)	1
35	1228	Screw for 20024	防塵カバー(下)止ネジ	2
36	20018	Front Cover Hinge Gasket	前カバーヒンジパッキン	1
37	20015	Front Cover Hinge	前カバーヒンジ	1
38	4440	Screw for 20015	前カバーヒンジ止ネジ	3
39	20016	Front Cover Hinge Pin	前カバーヒンジピン	1
40	3637	Screw for 20016	前カバーヒンジピン止ネジ	1
41	800	Threading Chart (Right)	糸通シ図	1
42	801	Threading Chart (Left)	糸通シ図	1
43	20010	Front Cover	前カバー	1
44	20017	Front Cover Hinge Spring	前カバーヒンジバネ	1
45	20600	Model Plate for Z 3000	型式板 Z 3000	1
45-1	20601	" " for Z 3002	型式板 Z 3002	1
46	—	Gauge Indicate Plate (See the table.)	ゲージ記号板(下表参照)	1
47	—	Device Indicate Plate (See Page 16, 17)	デバイス記号板(16, 17ページ参照)	1

Gauge Indicate Plate	Parts No.	Gauge Indicate Plate	Parts No.	Gauge Indicate Plate	Parts No.
A 3 D F	20802	C 5 D F	20810	Y 3 D F	20800
A 3 D A	20803	C 5 D A	20811	Y 3 D A	20801
A 4 D F	20806	C 6 D F	20812	Y 4 D F	20804
A 4 D A	20807	C 6 D A	20813	Y 4 D A	20805
A 5 D F	20808	C 7 D F	20818		
A 5 D A	20809	C 7 D A	20819		
A 6 D F	20816				
A 6 D A	20817				

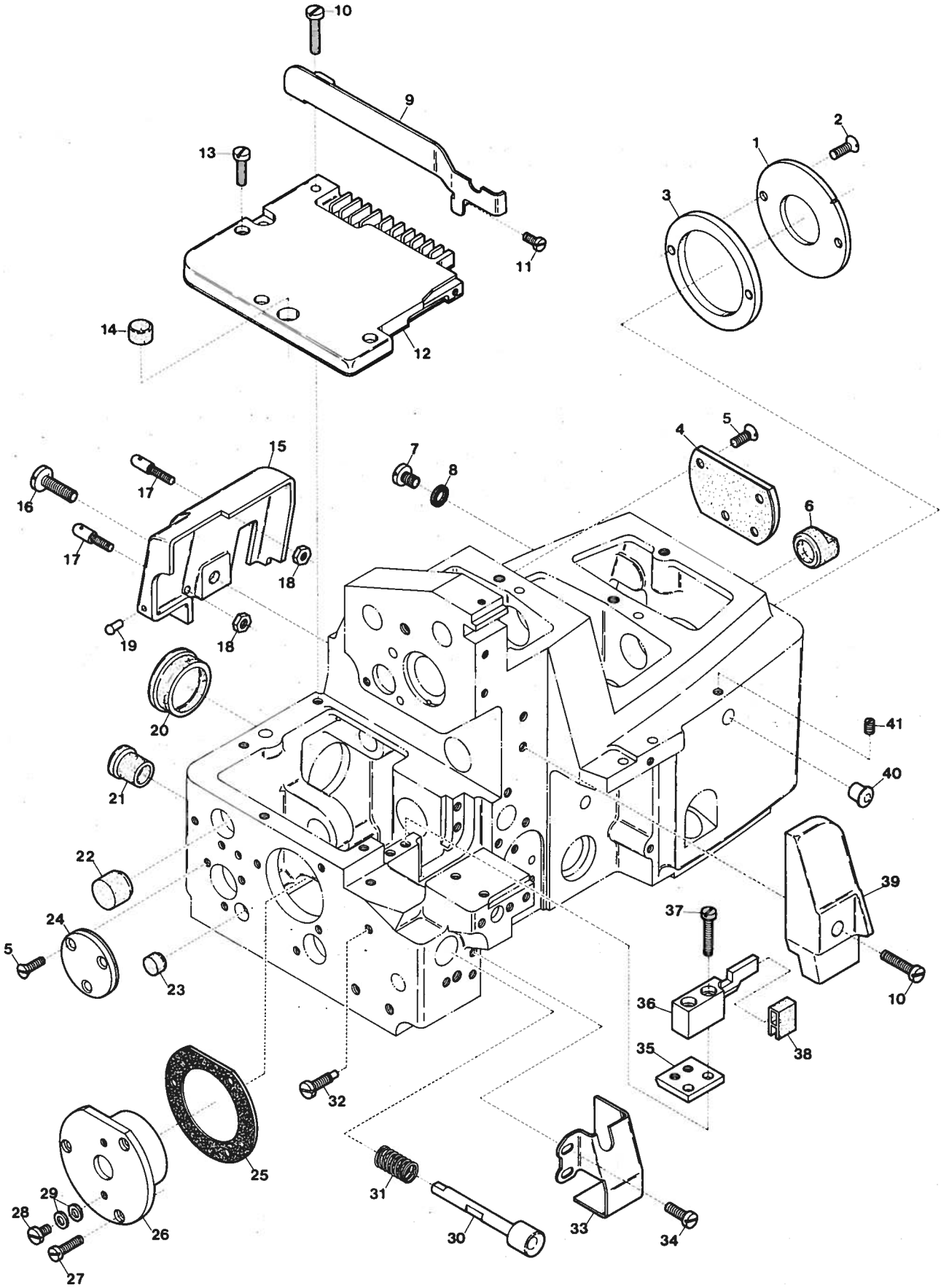

Ref. No.	Parts No.	Description	品名	Amt. Req.
1	20162	Ball Bearing Holder	ベアリング押工	1
2	1732	Screw for 20162	ベアリング押工止ネジ	2
3	20163	Ball Bearing Spacer	ベアリングスベサ	1
4	20060	Needle Driving Shaft End Cap	針振り軸蓋	1
5	5345	Screw for 20060, 33013	止ネジ	7
6	20061	Upper Knife Driving Shaft Oil Shield	上メス軸詰栓	1
7	7678	Screw for Machine Frame	フレームネジ蓋	1
8	188	Seal for 7678	フレームネジ蓋パッキン	1
9	20043	Fabric Guide	クロスプレート布案内	1
10	4441	Screw for 20043, 20022	止ネジ	2
11	4314	Screw for 20043	クロスプレート止ネジ	1
12	20042	Feed Mechanism Cover	送り台カバー	1
13	4437	Screw for 20042	送り台カバー止ネジ	3
14	20072	Rubber Cushion	埋メ座(中)	1
15	20040	Rear Cover	後カバー	1
16	4635	Screw for 20040	後カバー止ネジ	1
17	38361	Rear Cover Thread Eyelet	後カバー糸道	2
18	331	Nut for 38361	ナット	2
19	726	Rivet for 20040	止メ銀	1
20	20047	Feed Adjusting Window Cap	送り調節窓蓋	1
21	20046	Double Chaining Looper Driving Shaft Oil Shield	二重環ルーバ軸詰栓	1
22	20052	Eccentric Pin Oil Shield	エキセンピン詰栓	1
23	20051	Feed Driving Connecting Rod Oil Shield	送りロッドピン詰栓	1
24	33013	Feed Driving Shaft End Cap	送り軸蓋	1
25	20161	Ball Bearing Housing Gasket	ハウジングパッキン	1
26	20160	Ball Bearing Housing	ホールベアリングハウジング	1
27	4406	Screw for 20160	ホールベアリングハウジング止ネジ	3
28	9932	Screw for 20160	ネジ蓋	1
29	550	Seal for 20160	パッキン	2
30	20437	Feed Regulating Pushbutton	フッシュボタン	1
31	33131	Feed Regulating Pushbutton Spring	フッシュボタンハネ	1
32	5094	Screw for 20437	フッシュボタンガイドネジ	1
33	20021	Front Cover (Left)	前カバー(左)	1
34	4438	Screw for 20021	前カバー(左)止ネジ	2
35	20228	Stitch Plate Stay Spacer	針板支エスベサ	1
36	20221	Stitch Plate Stay	針板支工	1
37	9931	Screw for 20221	針板支工止ネジ	2
38	20229	Stitch Plate Stay Rubber Cushion	針板支工ゴム	1
39	20022	Dust-Free Cover (Upper)	防塵カバー(上)	1
40	32612	Packing Piece	詰栓	1
41	3434	Screw for 32612	詰栓止ネジ	1

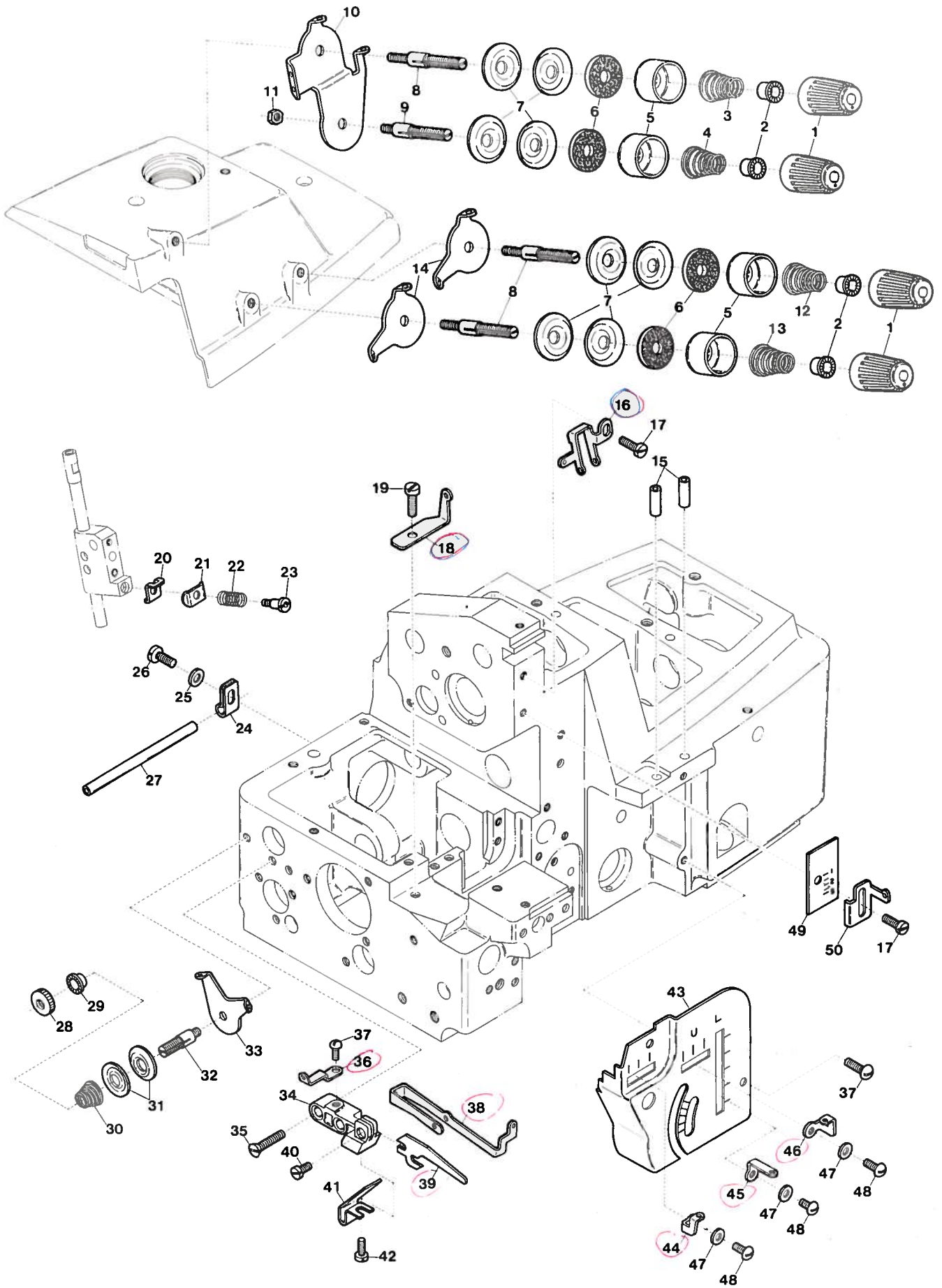

Ref. No.	Parts No.	Description	品名	Amt. Req.
1	20104	Thread Tension Spring Cap	糸調子バネキャップ	4
2	33890	Tension Spring Bushing	糸調子ナット回り止め	4
3	20132	Tension Spring (Overlock Stitch)	渦巻バネ(オーバロック針糸)	1
4	30255	Tension Spring (Double Chain Stitch)	渦巻バネ(二重環針糸)	1
5	20118	Thread Tension Spring Retainer	渦巻バネキャップ(下)	4
6	178	Felt for 31111	フェルト	4
7	31111	Tension Disc	糸調子皿	8
8	7904	Tension Post (Long)	糸調子棒(長)	3
9	4125	Tension Post (Short)	糸調子棒(短)	1
10	20100	Tension Disc Eyelet for Needle Thread	調子台糸道(大)	1
11	340	Nut for 4125	ナット	1
12	20102	Lower Looper Tension Spring	下ルーバ渦巻バネ	1
13	20103	Upper Looper Tension Spring	上ルーバ渦巻バネ	1
14	20101	Tension Disc Eyelet for Looper Thread	調子台糸道(小)	2
15	20106	Looper Thread Tube	糸道パイプ(短)	2
16	20113	Overedging Needle Thread Eyelet	針糸道	1
17	4353	Screw for 20113, 20114	止ネジ	2
18	20128	Double Chaining Looper Thread Eyelet	二重環ルーバ糸道	1
19	9853	Screw for 20128	二重環ルーバ糸道止ネジ	1
20	20115	Thread Retainer Bracket	小調子台	1
21	20116	Thread Retainer Plate	小調子皿	1
22	20131	Thread Retainer Sprng	小調子皿バネ	1
23	4114	Screw for 20131	小調子皿バネ止ネジ	1
24	93528	Looper Thread Eyelet Pipe Stay	糸道パイプ支工	1
25	541	Washer for 93528	ワッシャ	1
26	4440	Screw for for 93528	糸道パイプ支工止ネジ	1
27	20119	Looper Thread Eyelet Pipe	糸道パイプ(長)	1
28	182	Thread Tension Spring Nut	調節ナット	1
29	20126	Tension Spring Bushing	二重環糸調子ナット回り止め	1
30	20125	Double Chaining Looper Tension Spring	二重環糸調子バネ	1
31	20124	Tension Disc	二重環糸調子皿	2
32	4120	Tension Post	糸調子棒	1
33	20123	Tension Disc Eyelet for Double Chaining Looper Thread	二重環調子台糸道	1
34	20122	Thread Eyelet Bracket	二又糸道台	1
35	1733	Screw for 20122	二又糸道台止ネジ	2
36	32960	Double Chaining Looper Thread Eyelet (Left)	二重環ルーバ糸道(左)	1
37	1326	Screw for 32960, 20107	止ネジ	3
38	20120	Double Chaining Looper Thread Eyelet	二又糸道	1
39	20121	Thread Retaining Finger	糸案内	1
40	4320	Screw for 20121	糸案内止ネジ	1
41	38077	Double Chaining Looper Thread Eyelet Spring	二又糸道バネ	1
42	4358	Screw for 38077	二又糸道バネ止ネジ	1
43	20107	Looper Thread Eyelet Supporter	ルーバ糸道取付板	1
44	20109	Upper Looper Thread Eyelet (Left)	上ルーバ糸道(左)	1
45	20110	Lower Looper Thread Eyelet	下ルーバ糸道	1
46	20108	Upper Looper Thread Eyelet (Right)	上ルーバ糸道(右)	1
47	532	Washer for 20109, 20110, 20108	ワッシャ	3
48	1330	Screw for 20109, 20110, 20108	ルーバ糸道止ネジ	3
49	20129	Needle Thread Eyelet Graduation Plate	針糸道目盛板	1
50	20114	Double Chaining Needle Thread Eyelet	二重環針糸道	1

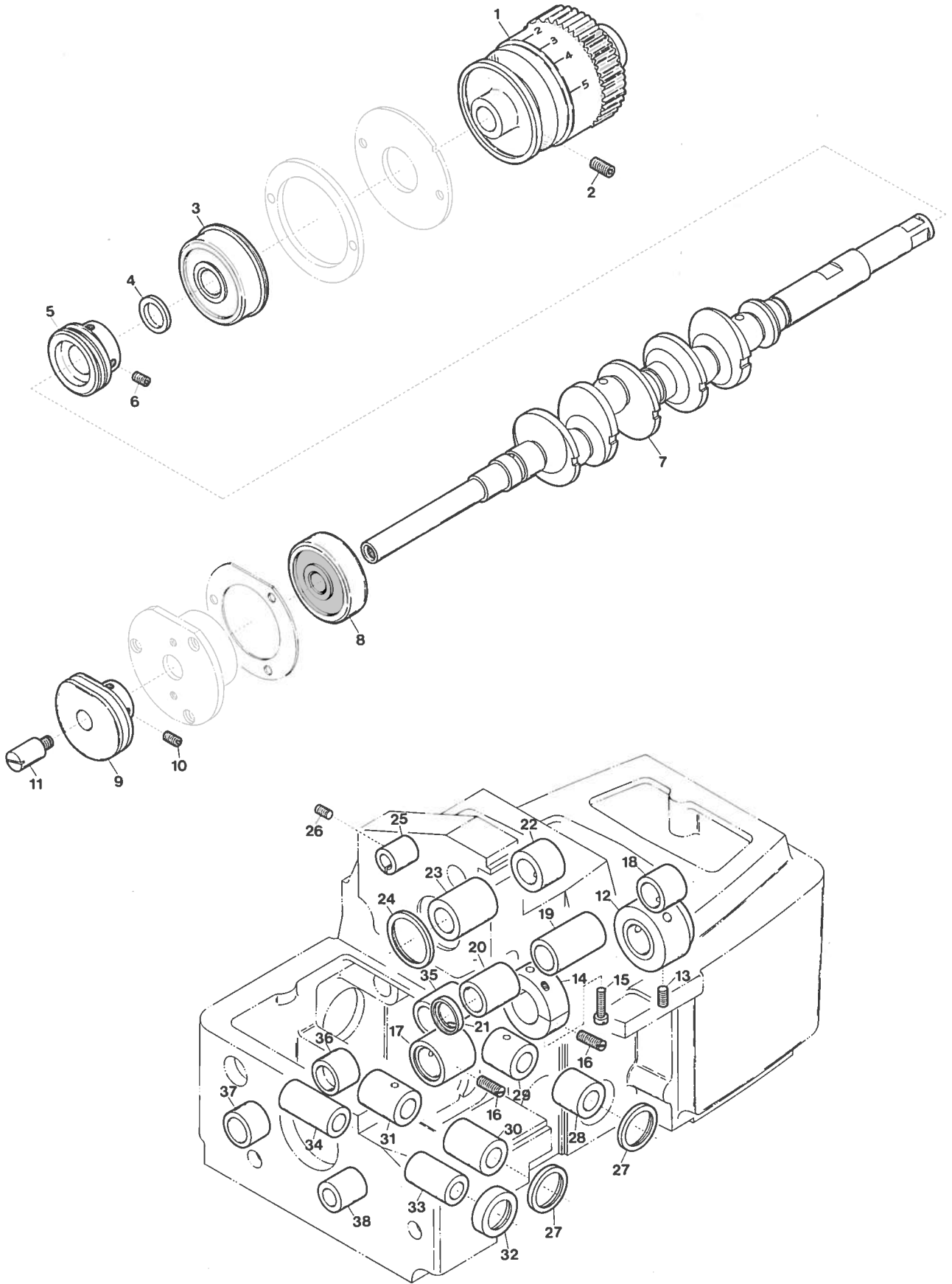

Ref. No.	Parts No.	Description	品名	Amt. Req.
1	20152	Pulley	プーリ	1
2	4123	Screw for 20152	プーリ止ネジ	2
3	20154	Crankshaft Ball Bearing (Large)	ボールベアリング(大)	1
4	32779	Crankshaft Ball Bearing Retaining Washer	ベアリング位置決めリング	1
5	20155	Oil Pump Driving Worm	ウォーム	1
6	4108	Screw for 20155	ウォーム止ネジ	2
7	20150	Crankshaft	クランクシャフト	1
8	20159	Crankshaft Ball Bearing (Small)	ボールベアリング(小)	1
9	20127	Double Chaining Looper Thread Take-up	糸調子カム	1
10	3638	Screw for 20127	糸調子カム止ネジ	2
11	20151	Thread Take-up Pin	糸調子カムピン	1
12	20156	Crankshaft Bushing (Right)	クランクシャフトブッシュ(右)	1
13	3434	Screw for 20156	クランクシャフトブッシュ(右)止ネジ	1
14	20157	Crankshaft Bushing (Center)	クランクシャフトブッシュ(中)	1
15	1170	Screw for 20157	クランクシャフトブッシュ(中)止ネジ	2
16	3654	Screw for 20157, 20158	止ネジ	2
17	20158	Crankshaft Bushing (Left)	クランクシャフトブッシュ(左)	1
18	20485	Upper Knife Driving Shaft Bushing (Right)	上メス軸ブッシュ(右)	1
19	20484	Upper Knife Driving Shaft Bushing (Center)	上メス軸ブッシュ(中)	1
20	20483	Upper Knife Driving Shaft Bushing (Left)	上メス軸ブッシュ(左)	1
21	32684	Upper Knife Driving Shaft Oil Seal	上メス軸オイルシール	1
22	20185	Needle Driving Shaft Bushing (Right)	針振り軸ブッシュ(右)	1
23	20186	Needle Driving Shaft Bushing (Left)	針振り軸ブッシュ(左)	1
24	20187	Needle Driving Shaft Oil Seal	針振り軸油切りリング	1
25	20194	Needle Driving Lever Link Shaft Bushing	針振りリンク軸ブッシュ	1
26	3632	Screw for 20194	針振りリンク軸ブッシュ止ネジ	1
27	20317	Looper Driving Shaft Oil Seal	ルーバ軸油切りリング	2
28	20315	Upper Looper Driving Shaft Bushing (Front)	上ルーバ軸ブッシュ(前)	1
29	20316	Upper Looper Driving Shaft Bushing (Rear)	上ルーバ軸ブッシュ(後)	1
30	20344	Lower Looper Driving Shaft Bushing (Front)	下ルーバ軸ブッシュ(前)	1
31	20345	Lower Looper Driving Shaft Bushing (Rear)	下ルーバ軸ブッシュ(後)	1
32	20368	Double Chaining Looper Driving Shaft Oil Seal	二重環ルーバ軸油切りリング	1
33	20366	Double Chaining Looper Driving Shaft Bushing (Front)	二重環ルーバ軸ブッシュ(前)	1
34	20367	Double Chaining Looper Driving Shaft Bushing (Rear)	二重環ルーバ軸ブッシュ(後)	1
35	20412	Feed Bar Driving Shaft Bushing (Right)	送り軸ブッシュ(右)	1
36	20411	Feed Bar Driving Shaft Bushing (Center)	送り軸ブッシュ(中)	1
37	20410	Feed Bar Driving Shaft Bushing (Left)	送り軸ブッシュ(左)	1
38	20435	Differential Feed Control Lever Shaft Bushing	送り調節レバー軸ブッシュ	1

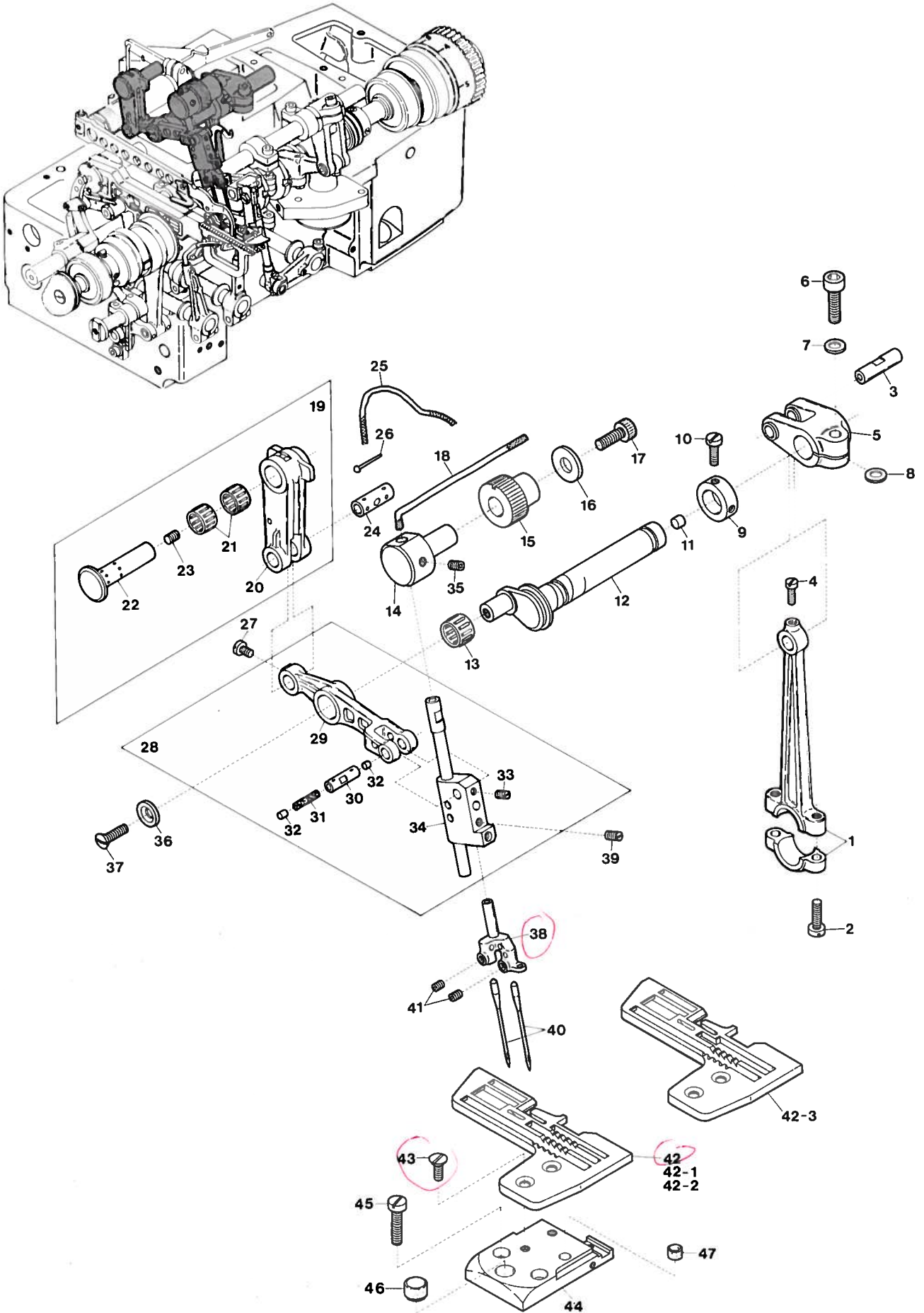

Ref. No.	Parts No.	Description	品名	Amt. Req.
1	20180	Needle Driving Connecting Rod	針ロッド	1
2	5070	Screw for 20180	針ロッド止ネジ	2
3	20181	Connecting Rod Pin	針ロッドピン	1
4	9508	Screw for 20181	針ロッドピン止ネジ	1
5	20182	Needle Driving Shaft Lever	針振り軸腕	1
6	5520	Screw for 20182	針振り軸腕止ネジ	1
7	567	Washer for 20182	ワッシャ	1
8	520	Packing Ring for 20182	パッキン	1
9	32646	Needle Driving Shaft Collar	針振り軸カラー	1
10	9604	Screw for 32646	針振り軸カラー止ネジ	2
11	750	Seal Plug for 20184	詰栓	1
12	20184	Needle Driving Shaft	針振り軸	1
13	93212	Roller Bearing for 20184	ニードルベアリング	1
14	20198	Needle Guide Bar Holder	針案内棒ホルダ	1
15	20199	Needle Guide Bar Holder Bushing	針案内棒ホルダブッシュ	1
16	183	Washer for 20199	ワッシャ	1
17	5108	Screw for 20199	針案内棒ホルダブッシュ止ネジ	1
18	194	Oil Wick for 20198	油芯	1
19	20237	Needle Driving Lever Link, Complete Set	針振りリンク (組)	1
20	20192	Needle Driving Lever Link	針振りリンク	1
21	20189	Roller Bearing for 20193	ニードルベアリング	2
22	20193	Needle Driving Lever Link Shaft	針振りリンク軸	1
23	3434	Screw for 20193	針振りリンク軸止ネジ	1
24	20191	Needle Driving Lever Link Pin	針振りリンクピン	1
25	195	Oil Wick for 20192	油芯	1
26	755	Pin for Oil Wick	油芯止メピン	1
27	4401	Screw for 20191	針振りリンクピン止ネジ	1
28	20236	Needle Driving Lever, Complete Set	針振りレバー (組)	1
29	20188	Needle Driving Lever	針振りレバー	1
30	20195	Needle Driving Lever Pin	針振りレバーピン	1
31	199	Oil Wick for 20195	油芯	1
32	720	Seal Plug for 20195	詰栓	2
33	1459	Screw for 20195	針振りレバーピン止ネジ	1
34	20235	Needle Driving Slider, Complete Set	針案内 (組)	1
35	3638	Screw for 20235	針案内 (組) 止ネジ	1
36	20190	Needle Driving Lever Washer	針振りレバー押工	1
37	7128	Screw for 20190	針振りレバー押工止ネジ	1
38	20200	Needle Clamp	針止メ	1
39	1457	Screw for 20200	針止メ止ネジ	1
40		Needle (System:DC×27)	針	2
41	3637	Screw for Needle	針止ネジ	2
42	20210	Stitch Plate (A4)	針板 A4	1
42-1	20211	" (A5)	" A5	1
42-2	20215	" (A6)	" A6	1
42-3	20209	" (A3)	" A3	1
43	5345	Screw for Stitch Plate	針板止ネジ	2
44	20220	Stitch Plate Supporter	針板受け	1
45	9150	Screw for 20220	針板受け止ネジ	2
46	32604	Rubber Cushion (Large)	埋メ座 (大)	1
47	38221	Rubber Cushion (Small)	埋メ座 (小)	1

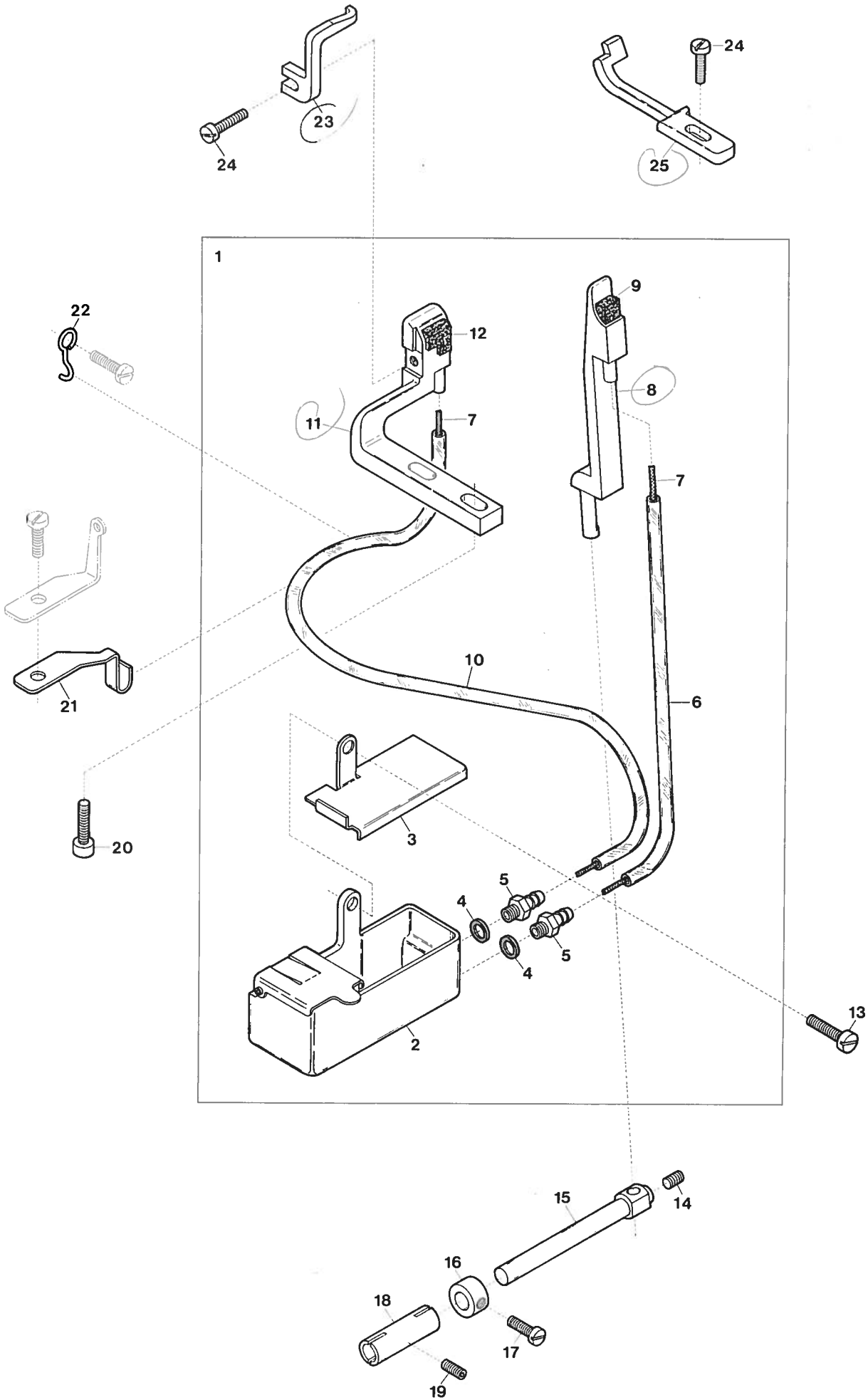

Ref. No.	Parts No.	Description	品名	Amt. Req.
1	20655	HR Unit, Complete Set	H R 装置 (組)	1
2	20654	HR Cup, Complete Set	H R カップ (組)	1
3	20651	Lid (Right) for HR Cup	H R カップフタ (右)	1
4	187	Seal for 10017	パッキン	2
5	10017	Pipe Joint	パイプ継手	2
6	20652	Oil Tube (82mm) for Overlock Stitch	給油パイプオーバ側	1
7		Oil Wick	油芯 (毛糸)	2
8	20224	Needle Guard (Rear) (Overlock Stitch)	オーバ針受ケ (後)	1
9	189	Felt for HR Unit	フェルト	1
10	20653	Oil Tube (170mm) for Double Chain Stitch	給油パイプインタ側	1
11	20227	Needle Guard (Rear) (Double Chain Stitch)	インタ針受ケ (後)	1
12	190	Felt for HR Unit	フェルト	1
13	4440	Screw for 20654	H R カップ (組) 止ネジ	1
14	3638	Screw for 20224	オーバ針受ケ (後) 止ネジ	1
15	20230	Needle Guard Supporter	針受ケ取付台	1
16	20376	Needle Guard Supporter Collar	針受ケ取付台カラー	1
17	1208	Screw for 20376	針受ケ取付台カラー止ネジ	1
18	20225	Bushing for 20224	オーバ針受ケ (後) ブッシュ	1
19	3632	Screw for 20225	オーバ針受ケ (後) ブッシュ止ネジ	1
20	5098	Screw for 20227	インタ針受ケ (後) 止ネジ	2
21	20656	Oil Tube Holder (Upper)	H R パイプ支エ (上)	1
22	20657	Oil Tube Holder (Lower)	H R パイプ支エ (下)	1
23	20226	Needle Guard (Front) (Double Chain Stitch)	インタ針受ケ (前)	1
24	4404	Screw for 20226, 20223	止ネジ	2
25	20223	Needle Guard (Front) (Overlock Stitch)	オーバ針受ケ (前)	1

Note: HR Unit.....Silicone Oil Supplying Unit for Needle Cooling.

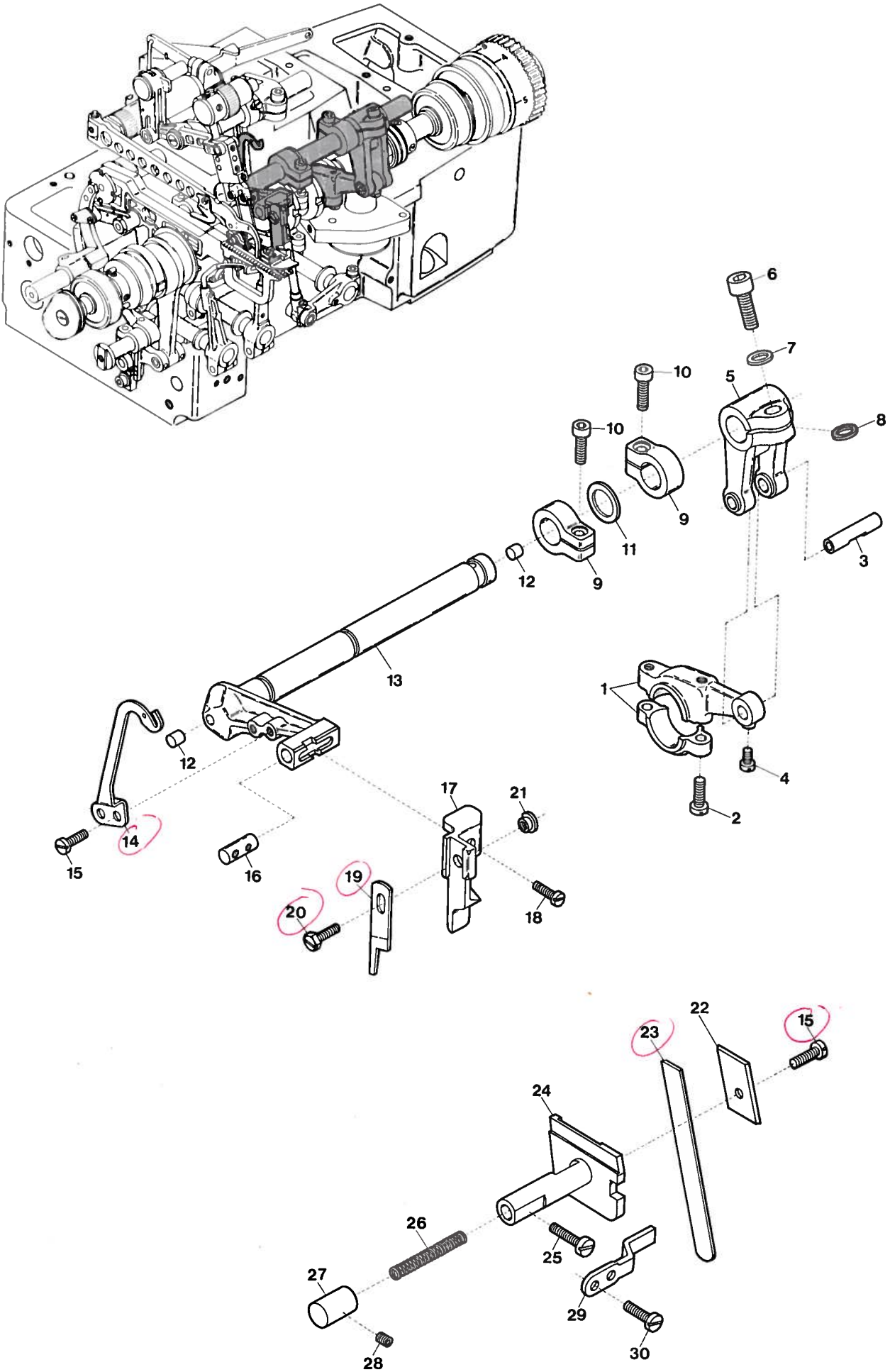

UPPER KNIFE DRIVING & LOWER KNIFE MECHANISM

Ref. No.	Parts No.	Description	品名	Amt. Req.
1	20480	Upper Knife Driving Connecting Rod	上メスロッド	1
2	5070	Screw for 20480	上メスロッド止ネジ	2
3	20180	Connecting Rod Pin	上メスロッドピン	1
4	9508	Screw for 20180	上メスロッドピン止ネジ	1
5	20481	Upper Knife Driving Lever	上メス軸腕	1
6	5520	Screw for 20481	上メス軸腕止ネジ	1
7	520	Washer for 5520	ワッシャ	1
8	567	Packing Ring for 20481	パッキン	1
9	32920	Upper Knife Driving Shaft Collar	上メス軸カラー	2
10	4129	Screw for 32920	上メス軸カラー止ネジ	2
11	20487	Thrust Washer	上メス軸スラストリング	1
12	750	Seal Plug for 20486	詰栓	2
13	20486	Upper Knife Driving Shaft	上メス軸	1
14	20117	Needle Thread Pull-off	針糸繰り	1
15	4353	Screw for 20117, 20499	止ネジ	3
16	20490	Upper Knife Holder Positioner	上メスホルダ止メ	1
17	20494	Upper Knife Holder (Flat Type)	上メスホルダ(平)	1
18	7405	Screw for 20494	上メスホルダ止ネジ	1
19	20496	Upper Knife (Flat Type)	上メス(平)	1
20	4106	Screw for 20496	上メス止ネジ	1
21	20495	Upper Knife Holder (Flat) Fixing Nut	上メスホルダ(平)埋メ座	1
22	20499	Lower Knife Clamp	下メス押エ	1
23	20498	Lower Knife	下メス	1
24	20497	Lower Knife Holder	下メス台	1
25	4591	Screw for 20497	下メス台止ネジ	1
26	32919	Lower Knife Holder Spring	下メスバネ	1
27	20500	Lower Knife Holder Spring Stopper	下メスバネ受ケ	1
28	3638	Screw for 20500	下メスバネ受ケ止ネジ	1
29	32899	Lower Knife Holder Locking Plate	下メス台回り止メ	1
30	4440	Screw for 32899	下メス台回り止メ止ネジ	2

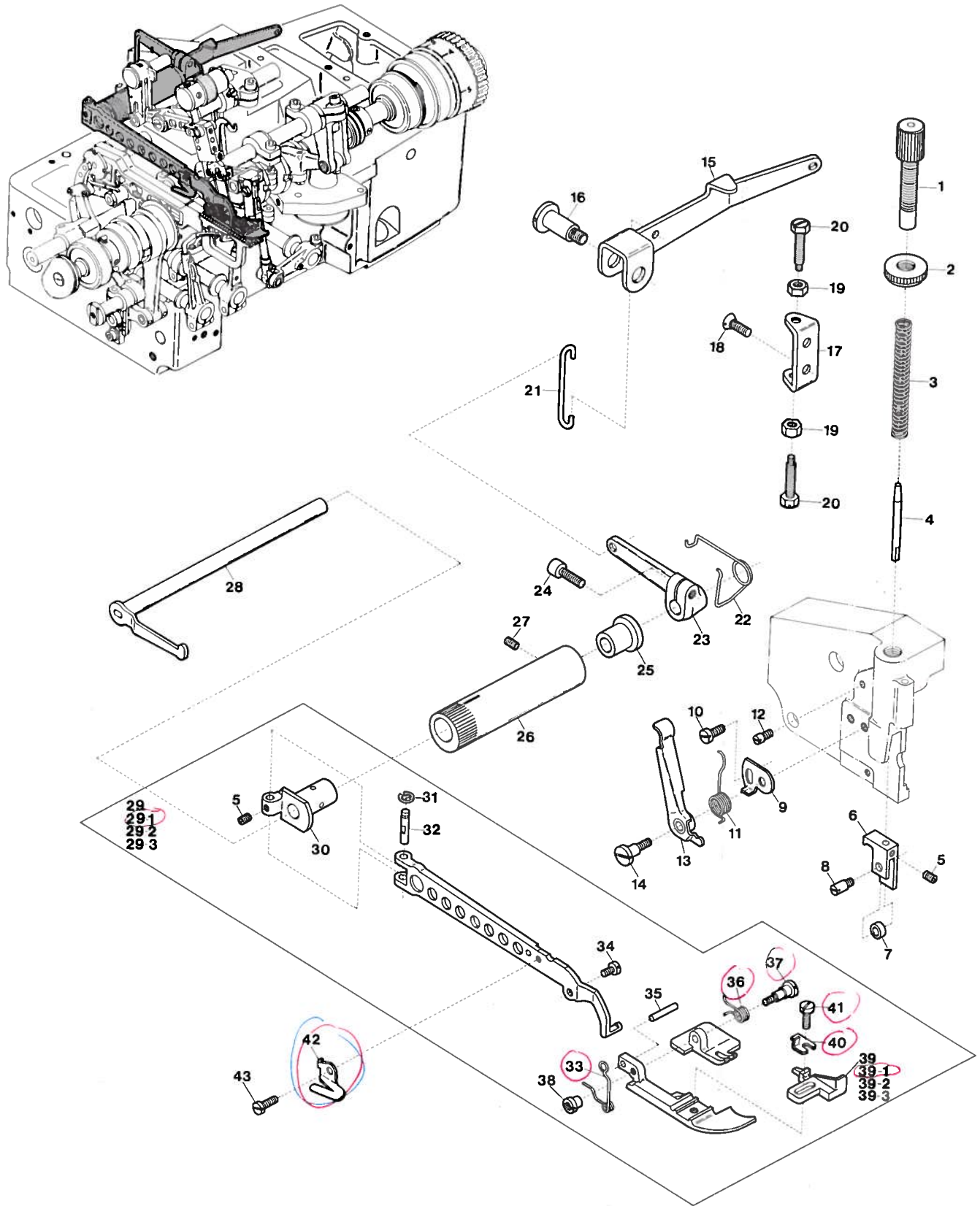

Ref. No.	Parts No.	Description	品名	Amt. Req.
1	4119	Presser Spring Adjusting Screw	押工バネ調節ネジ	1
2	461	Presser Spring Lock Nut	調節ネジナット	1
3	20287	Presser Spring	押工バネ	1
4	20286	Presser Spring Guide Pin	押工バネ案内ピン	1
5	3637	Screw for 20286, 20272	止ネジ	2
6	20284	Presser Foot Positioning Guide	押工腕案内	1
7	34294	Presser Foot Rollar	押工ローラ	1
8	6405	Screw for 34294	押工ローラ止ネジ	1
9	20290	Presser Arm Stopper	押工腕ストッパ	1
10	5000	Screw for 20290	押工腕ストッパ止ネジ	2
11	20293	Presser Foot Release Lever Spring	手揚げバネ	1
12	4109	Screw for 20293	手揚げバネ掛ネジ	1
13	20292	Presser Foot Release Lever	手揚げ	1
14	4107	Screw for 20292	手揚げ止ネジ	1
15	20282	Presser Foot Lifter Lever	押工揚げレバー	1
16	4103	Screw for 20282	押工揚げレバー止ネジ	1
17	20283	Presser Foot Lifter Lever Stopper	押工揚げゲストッパ	1
18	9127	Screw for 20283	押工揚げゲストッパ止ネジ	2
19	334	Nut for 20282	押工揚げレバー調節ナット	2
20	5505	Adjusting Screw for 20282	押工揚げレバー調節ネジ	2
21	20281	Presser Foot Lifter Lever Connecting Link	押工揚げレバーリンク	1
22	20280	Intermediate Lever Spring	押工揚げ軸バネ	1
23	20279	Intermediate Lever	押工揚げ軸レバー	1
24	5550	Screw for 20279	押工揚げ軸レバー止ネジ	1
25	20275	Presser Foot Lifter Lever Shaft Guide	押工揚げ軸スリーブ	1
26	20274	Presser Foot Lifter Lever Shaft Bushing	押工揚げ軸ブッシュ	1
27	3632	Screw for 20274	押工揚げ軸ブッシュ止ネジ	1
28	20276	Presser Foot Lifter Lever Shaft	押工揚げ軸	1
29	20294	Presser Foot, Complete Set (A3)	押工(組) A3	1
29-1	20291	" (A4)	押工(組) A4	1
29-2	20295	" (A5)	押工(組) A5	1
29-3	20296	" (A6)	押工(組) A6	1
30	20273	Presser Arm Hinge	押工腕ヒンジ	1
31	34293	Retaining Ring	Eリング	1
32	20272	Presser Arm Hinge Pin	押工腕ヒンジピン	1
33	20254	Presser Foot Spring (Large)	押工バネ(大)	1
34	1222	Screw for 20254	押工バネ(大)止ネジ	1
35	731	Pin for 20255	押工バネ(小)止メピン	1
36	20255	Presser Foot Spring (Small)	押工バネ(小)	1
37	4128	Screw for 20255	押工バネ(小)止ネジ	1
38	216	Nut for 4128	ナット	1
39	20257	Presser Foot Stitch Tongue (3)	爪3	1
39-1	20256	" (4)	爪4	1
39-2	20262	" (5)	爪5	1
39-3	20258	" (6)	爪6	1
40	20253	Presser Foot Hinge Spring	押工ヒンジバネ	1
41	4131	Screw for 20253	押工ヒンジバネ止ネジ	1
42	20271	Thread Chain Cutting Knife	チェーンカッター	1
43	4236	Screw for 20271	チェーンカッター止ネジ	1

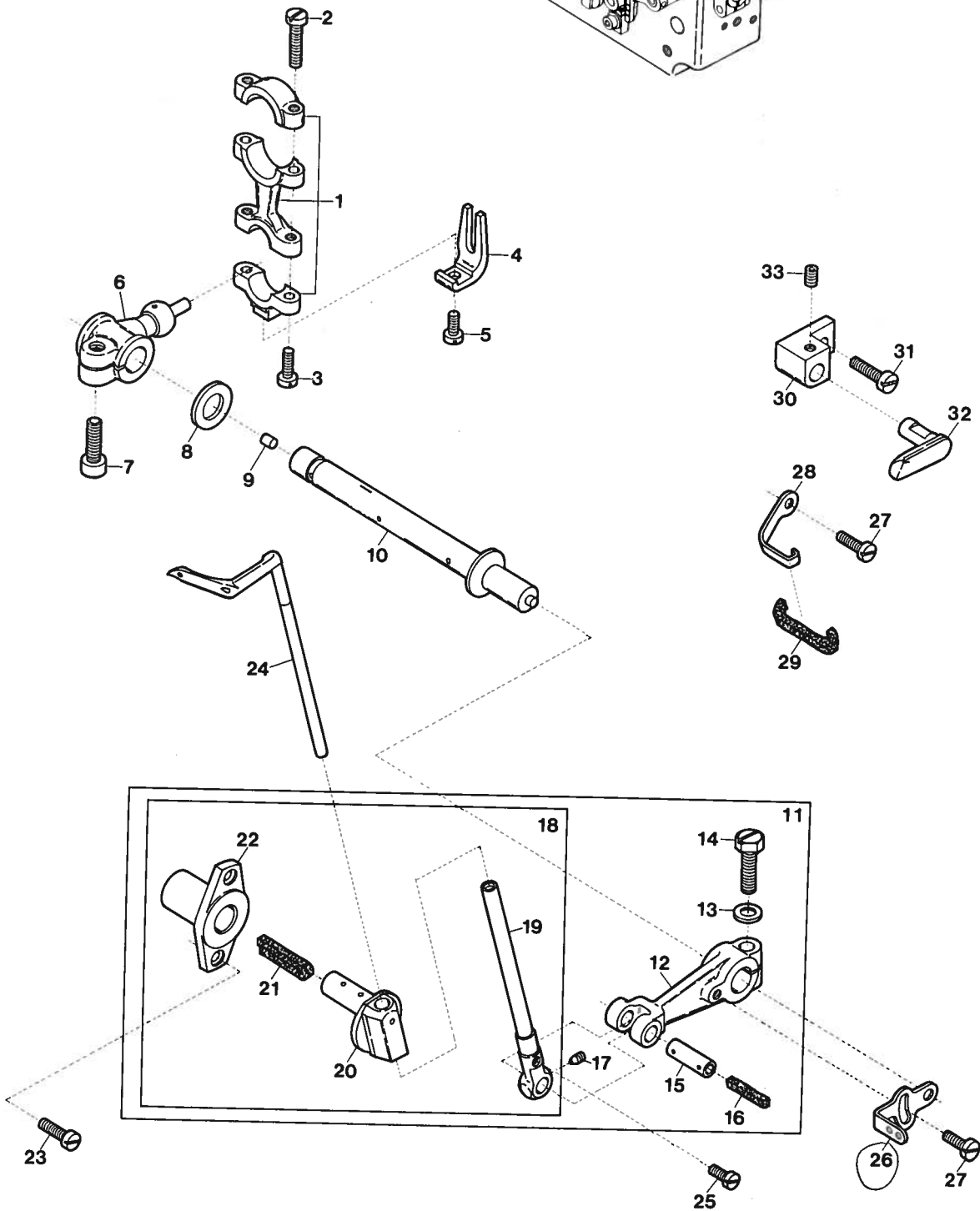
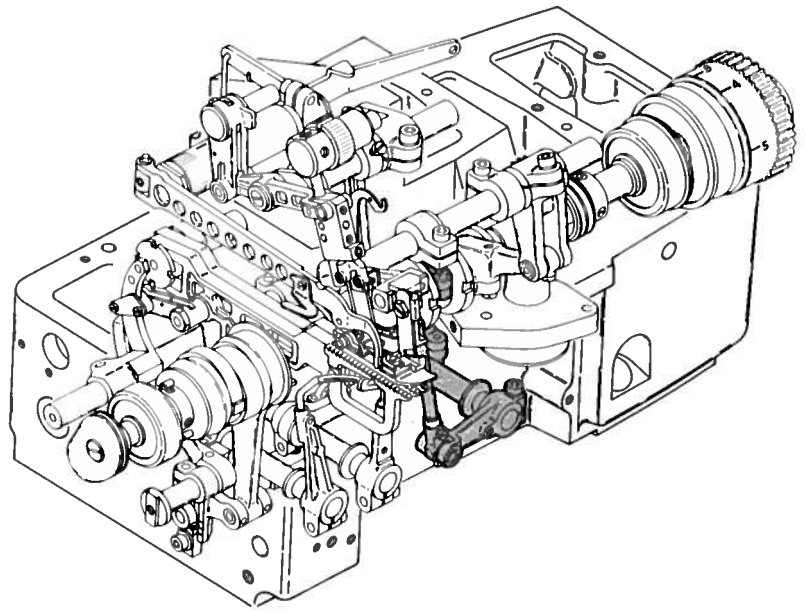

Ref. No.	Parts No.	Description	品名	Amt. Req.
1	20310	Upper Looper Driving Lever Connecting Rod	上ルーパロッド	1
2	5070	Screw for 20310	上ルーパロッド止ネジ	2
3	4121	Screw for 20310	上ルーパロッド止ネジ	2
4	20311	Ball Joint Guide Fork	振レ止メ	1
5	4351	Screw for 20311	振レ止メ止ネジ	1
6	20312	Upper Looper Driving Lever	上ルーパ軸腕	1
7	5108	Screw for 20312	上ルーパ軸腕止ネジ	1
8	20314	Thrust Washer	スラストリング	1
9	740	Seal Plug for 20313	詰栓	1
10	20313	Upper Looper Driving Shaft	上ルーパ軸	1
11	20328	Upper Looper Bar Driving Arm, Complete Set	上ルーパ腕(組)	1
12	20318	Upper Looper Bar Driving Arm	上ルーパ腕	1
13	520	Washer for 20318	ワッシャ	1
14	5522	Screw for 20318	上ルーパ腕止ネジ	1
15	20331	Upper Looper Bar Driving Arm Pin	ルーパ腕ピン	1
16	278	Oil Wick for 20331	油芯	1
17	3313	Screw for 20331	ルーパ腕ピン止ネジ	1
18	20326	Upper Looper Bar, Complete Set	ルーパ棒(組)	1
19	20319	Upper Looper Bar	ルーパ棒	1
20	20320	Upper Looper Bar Guide	ルーパ案内	1
21	304	Oil Wick for 20320	油芯	1
22	20321	Upper Looper Bar Guide Bushing	ルーパ案内ブッシュ	1
23	9508	Screw for 20321	ルーパ案内ブッシュ止ネジ	2
24	20324	Upper Looper	上ルーパ	1
25	1208	Screw for 20324	上ルーパ止ネジ	1
26	20112	Looper Thread Pull-off	ルーパ糸繰り	1
27	4358	Screw for 20112, 20330	止ネジ	2
28	20330	Looper Bar Oil Wick Holder Plate	ルーパ棒油芯止メ板	1
29	447	Oil Wick for 20319	油芯	1
30	20322	Looper Bar Guide Holder Bracket	ルーパ案内押工台	1
31	4437	Screw for 20322	ルーパ案内押工台止ネジ	1
32	20323	Looper Bar Guide Holder	ルーパ案内押工	1
33	3638	Screw for 20323	ルーパ案内押工止ネジ	1

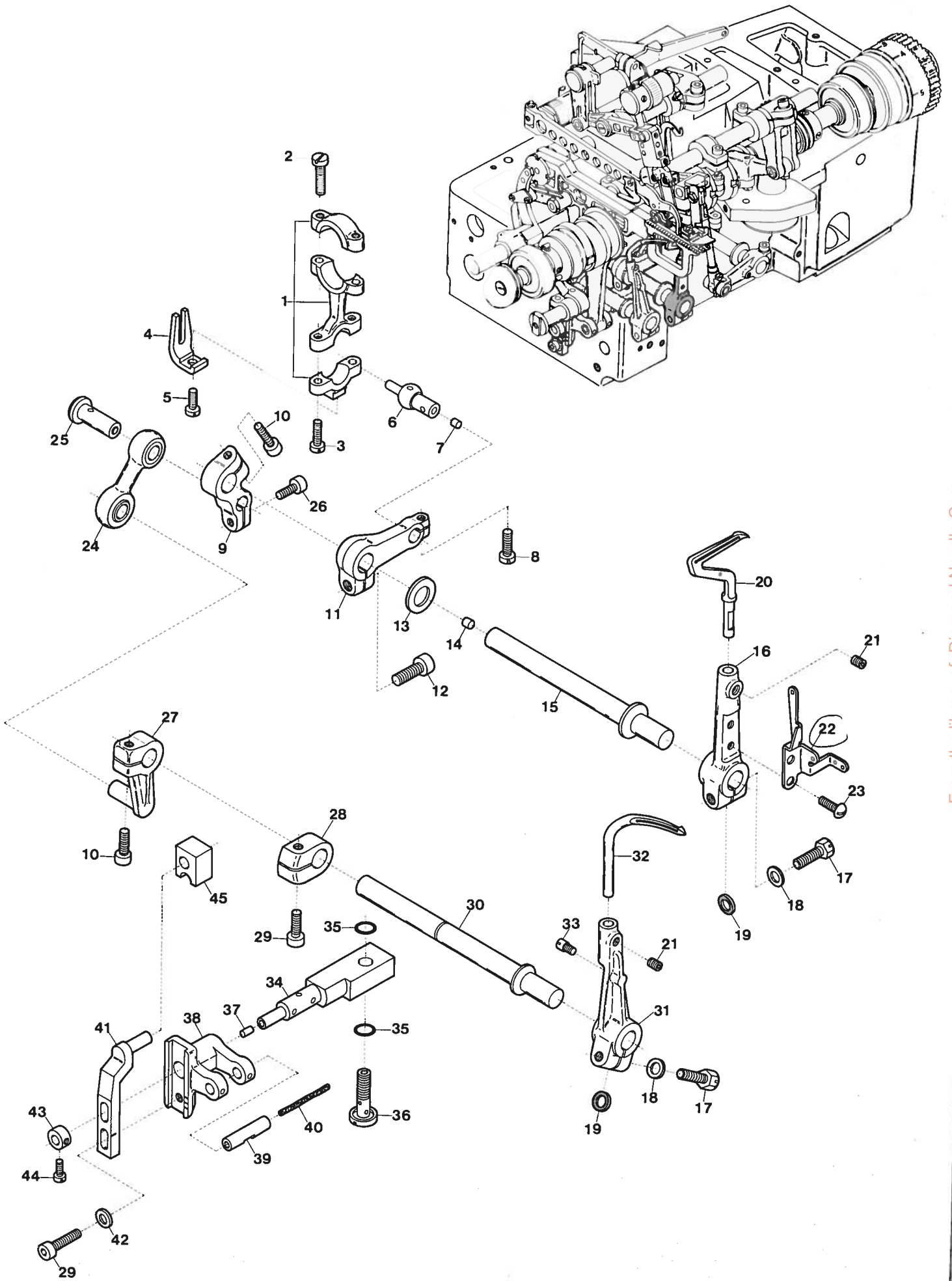

LOWER & DOUBLE CHAINING LOOPER DRIVING

下ルーパ及び 二重環ルーパ機構

MECHANISM

Ref. No.	Parts No.	Description	品名	Amt. Req.
1	20340	Lower Looper Driving Lever Connecting Rod	下ルーパロッド	1
2	5070	Screw for 20340	下ルーパロッド止ネジ	2
3	4121	Screw for 20340	下ルーパロッド止ネジ	2
4	20311	Ball Joint Guide Fork	振レ止メ	1
5	4351	Screw for 20311	振レ止メ止ネジ	1
6	20341	Ball Stud	下ルーパロッド球	1
7	720	Seal Plug for 20341	詰栓	1
8	4437	Screw for 20341	下ルーパロッド球止ネジ	1
9	20360	Looper Driving Shaft Lever	ルーパ振り腕	1
10	5650	Screw for 20360, 20364	止ネジ	2
11	20342	Lower Looper Driving Lever	下ルーパ軸腕	1
12	5108	Screw for 20342	下ルーパ軸腕止ネジ	1
13	34118	Thrust Washer	スラストプレート	1
14	740	Seal Plug for 20343	詰栓	1
15	20343	Lower Looper Driving Shaft	下ルーパ軸	1
16	20346	Lower Looper Holder Arm	下ルーパ台	1
17	5500	Screw for 20346, 20377	止ネジ	2
18	520	Washer for 20346, 20377	ワッシャ	2
19	567	Packing Ring for 20346, 20377	パッキン	2
20	20347	Lower Looper	下ルーパ	1
21	3638	Screw for 20347, 20378	止ネジ	2
22	20111	Looper Thread Pull-off	下ルーパ糸繰り	1
23	1326	Screw for 20111	下ルーパ糸繰り止ネジ	2
24	33606	Double Chaining Looper Driving Connection	二重環ルーパリンク	1
25	20361	Looper Driving Connection Guide Pin	ルーパリンクピン	1
26	5040	Screw for 20361	二重環ルーパリンクピン止ネジ	1
27	20364	Double Chaining Looper Driving Lever	二重環ルーパ軸腕	1
28	33071	Double Chaining Looper Driving Shaft Collar	二重環ルーパ軸カラー	1
29	5550	Screw for 33071, 20374	止ネジ	2
30	20365	Double Chaining Looper Driving Shaft	二重環ルーパ軸	1
31	20377	Double Chaining Looper Holder Arm	二重環ルーパ台	1
32	20378	Double Chaining Looper	二重環ルーパ	1
33	3410	Stopper Screw for 20378	二重環ルーパストップパネジ	1
34	20373	Looper Rocker Shaft	ルーパ前後軸	1
35	20538	O-Ring	Oリング	2
36	4113	Oil Tube Fitting Stud	管継手ホルト	2
37	730	Oil Seal for 20373	詰栓	1
38	20372	Looper Rocker Shaft Arm	ルーパ前後軸腕	1
39	20371	Looper Connecting Rod Pin	ルーパ前後ロッドピン	1
40	197	Oil Wick for 20371	油芯	1
41	20374	Looper Avoiding Adjusting Lever	二重環前後量調節レバー	1
42	542	Washer for 20374	ワッシャ	1
43	20376	Looper Rocker Shaft Lever Collar	ルーパ前後軸腕カラー	1
44	1208	Screw for 20376	ルーパ前後軸腕カラー止ネジ	1
45	20375	Looper Slide Block	ルーパ前後駒	1

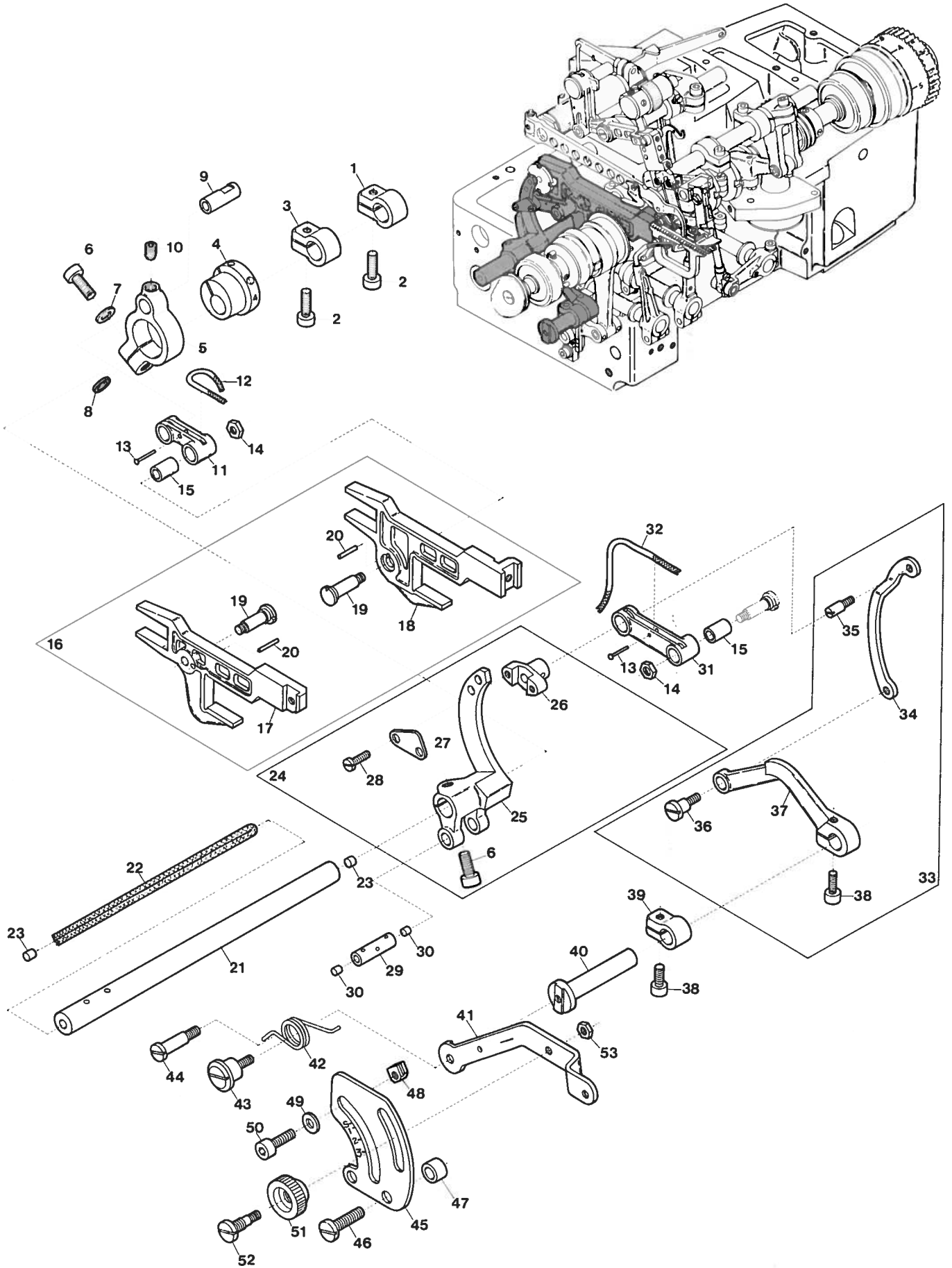

Ref. No.	Parts No.	Description	品名	Amt. Req.
1	20445	Feed Bar Driving Shaft Collar (Right)	送り軸カラー(右)	1
2	4129	Screw for 20445, 32920	止ネジ	2
3	32920	Feed Bar Driving Shaft Collar (Left)	送り軸カラー(左)	1
4	20423	Main Feed Bar Driving Lever Eccentric	後送り腕エキセン	1
5	20422	Main Feed Bar Driving Lever	後送り腕	1
6	5520	Screw for 20422, 20408	止ネジ	2
7	520	Washer for 20422	ワッシャ	1
8	567	Packing Ring for 20422	パッキン	1
9	20424	Main Feed Bar Driving Lever Pin	後送り腕ピン	1
10	3646	Screw for 20424	後送り腕ピン止ネジ	1
11	20425	Main Feed Bar Driving Connection	後送りリンク	1
12	193	Oil Wick for 20425	油芯	1
13	755	Pin for 193	油芯止ピン	2
14	451	Nut for 33098	ナット	2
15	33098	Feed Bar Driving Connection Bushing	送りリンクブッシュ	2
16	20442	Feed Bar, Complete Set	送り台(組)	1
17	20426	Differential Feed Bar	前送り台	1
18	20427	Main Feed Bar	後送り台	1
19	33099	Feed Bar Driving Stud	送りリンクピン	2
20	687	Pin for 33099	ピン	2
21	20409	Feed Bar Driving Shaft	送り軸	1
22	191	Oil Wick for 20409	油芯	1
23	750	Seal Plug for 20409	詰栓	2
24	20447	Differential Feed Rocker, Complete Set	前送り腕(組)	1
25	20408	Differential Feed Rocker	前送り腕	1
26	20413	Differential Feed Regulating Slide Pin	スライダ	1
27	20414	Differential Feed Regulating Slide Pin Cap	スライダキャップ	1
28	9624	Screw for 20414	スライダキャップ止ネジ	2
29	20407	Feed Bar Driving Connecting Rod Pin	送りロッドピン	1
30	730	Seal Plug for 20407	詰栓	2
31	33094	Differential Feed Bar Driving Connection	前送りリンク	1
32	192	Oil Wick for 33094	油芯	1
33	20444	Differential Feed Control Inner Lever, Complete Set	前送り調節リンク(組)	1
34	20415	Differential Feed Control Link	前送り調節リンク	1
35	5512	Screw for 20415	前送り調節リンク止ネジ	1
36	4100	Screw for 20416	前送り調節中レバー止ネジ	1
37	20416	Differential Feed Control Lever (Inner)	前送り調節中レバー	1
38	5550	Screw for 20416, 32792	止ネジ	2
39	32792	Differential Feed Control Lever Shaft Collar	前送り調節レバー軸カラー	1
40	20417	Differential Feed Control Lever Shaft	前送り調節レバー軸	1
41	20418	Differential Feed Control Lever (Outer)	前送り調節外レバー	1
42	20421	Differential Feed Control Lever Spring	調節外レバーバネ	1
43	4118	Screw for 20421	調節外レバーバネ止ネジ	1
44	4110	Screw for 20421	調節外レバーバネ掛ケネジ	1
45	20419	Differential Feed Graduation	送り目盛板	1
46	9930	Screw for 20419	送り目盛板止ネジ	2
47	185	Washer for 20419	ワッシャ	2
48	20420	Differential Feed Control Lever Stopper	調節外レバーストッパ	2
49	186	Washer for 20420	ワッシャ	2
50	5038	Screw for 20420	調節外レバーストッパ止ネジ	2
51	181	Adjusting Nut for 20418	調節ナット	1
52	4111	Adjusting Screw for 20418	調節ネジ	1
53	340	Nut for 4111	調節ネジ止ナット	1

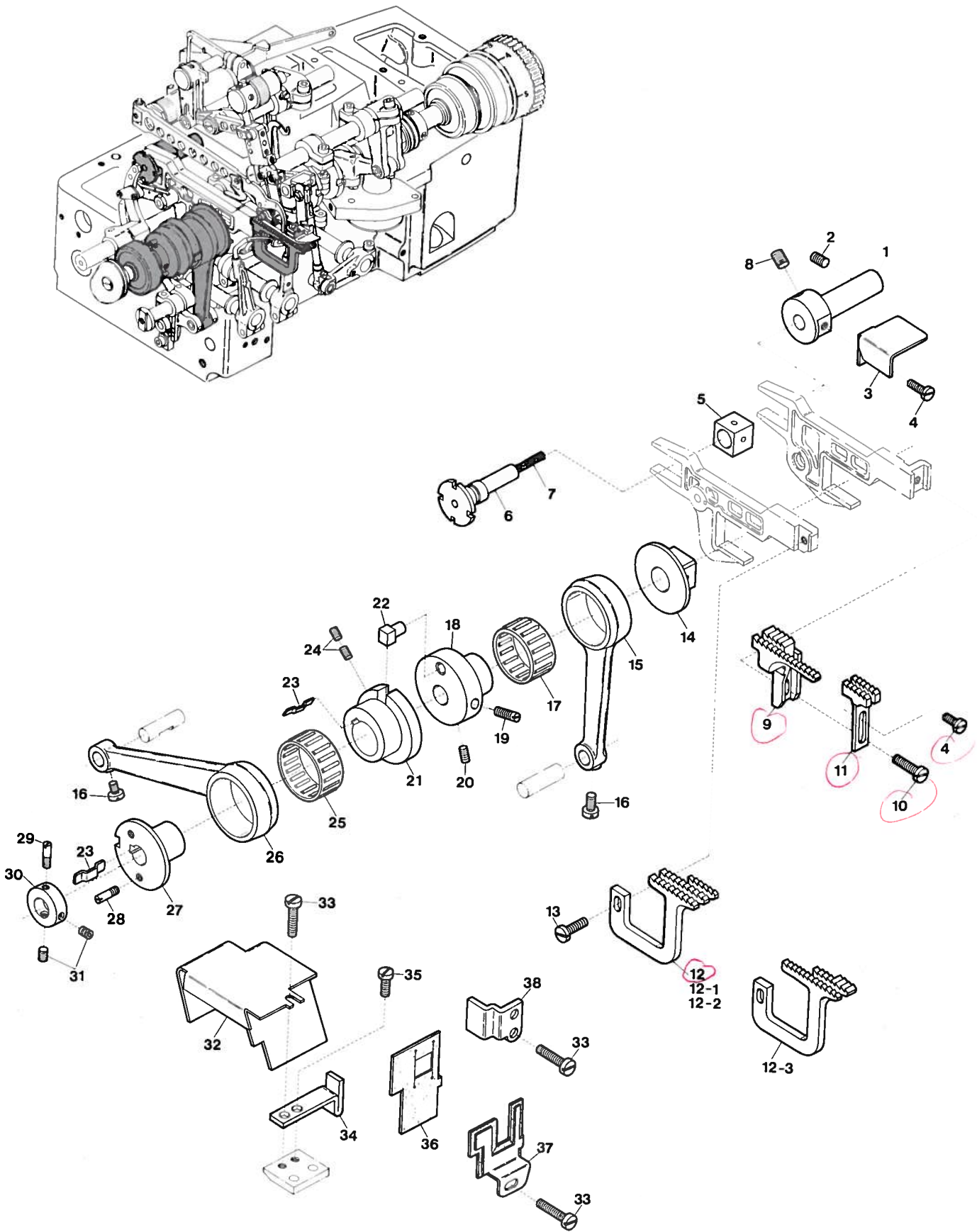

Ref. No.	Parts No.	Description	品名	Amt. Req.
1	33251	Feed Bar Guide (Rear)	送り台ガイド(後)	1
2	3632	Screw for 33251	送り台ガイド(後)止ネジ	1
3	33252	Feed Mechanism Rear Shield	送り台油除ケ	1
4	9730	Screw for 33252, 20441	止ネジ	2
5	32867	Feed Bar Guide Block	角駒(小)	1
6	33141	Feed Adjusting Eccentric Pin	エキセンピン	1
7		Oil Wick for 33141	油芯	1
8	3635	Screw for 33141	エキセンピン止ネジ	1
9	20440	Main Feed Dog	後送り	1
10	7609	Screw for 20440	後送り止ネジ	1
11	20441	Auxiliary Feed Dog	小送り	1
12	20439	Differential Feed Dog (4)	前送り4	1
12-1	20460	" (5)	前送り5	1
12-2	20452	" (6)	前送り6	1
12-3	20451	" (3)	前送り3	1
13	4353	Screw for Differential Feed Dog	前送り止ネジ	1
14	20432	Feed Lift Block	角駒(大)	1
15	20370	Looper Rocker Connecting Rod	ルーバ前後ロッド	1
16	9604	Screw for Connecting Rod Pin	止ネジ	2
17	33115	Roller Bearing for 20370	ニードルベアリング	1
18	20369	Looper Rocker Eccentric	ルーバ前後エキセン	1
19	3405	Screw for 20369	ルーバ前後エキセン止ネジ	1
20	3436	Screw for 20369	ルーバ前後エキセン止ネジ	1
21	20400	Feed Dog Regulating Eccentric	送りエキセン	1
22	20401	Feed Dog Regulating Eccentric Pin	送りエキセンピン	1
23	20403	Spring Plate for 20400, 20402	回り止メバネ	2
24	3637	Screw for 20403	回り止メバネ止ネジ	2
25	77322	Roller Bearing for 20406	ニードルベアリング	1
26	20406	Feed Dog Driving Connecting Rod	送りロッド	1
27	20402	Feed Dog Regulating Control Eccentric	送り調節エキセン	1
28	4112	Stopper Screw for 20402	送り調節エキセンストッパネジ	2
29	4109	Screw for 20402	送り調節エキセンストッパ	1
30	20405	Feed Dog Regulating Control Eccentric Collar	送り調節エキセンカラー	1
31	3638	Screw for 20405	送り調節エキセンカラー止ネジ	2
32	20450	Feed Dog Driving Connecting Rod Cover	送りロッドカバー	1
33	4440	Screw for 20450, 20433, 20429	止ネジ	4
34	20428	Feed Bar Guide (Left)	送り台ガイド(左)	1
35	9853	Screw for 20428	送り台ガイド(左)止ネジ	1
36	20430	Feed Bar Shield	送り台シール	1
37	20433	Feed Mechanism Front Shield	送り前カバー	1
38	20429	Feed Bar Guide (Right)	送り台ガイド(右)	1

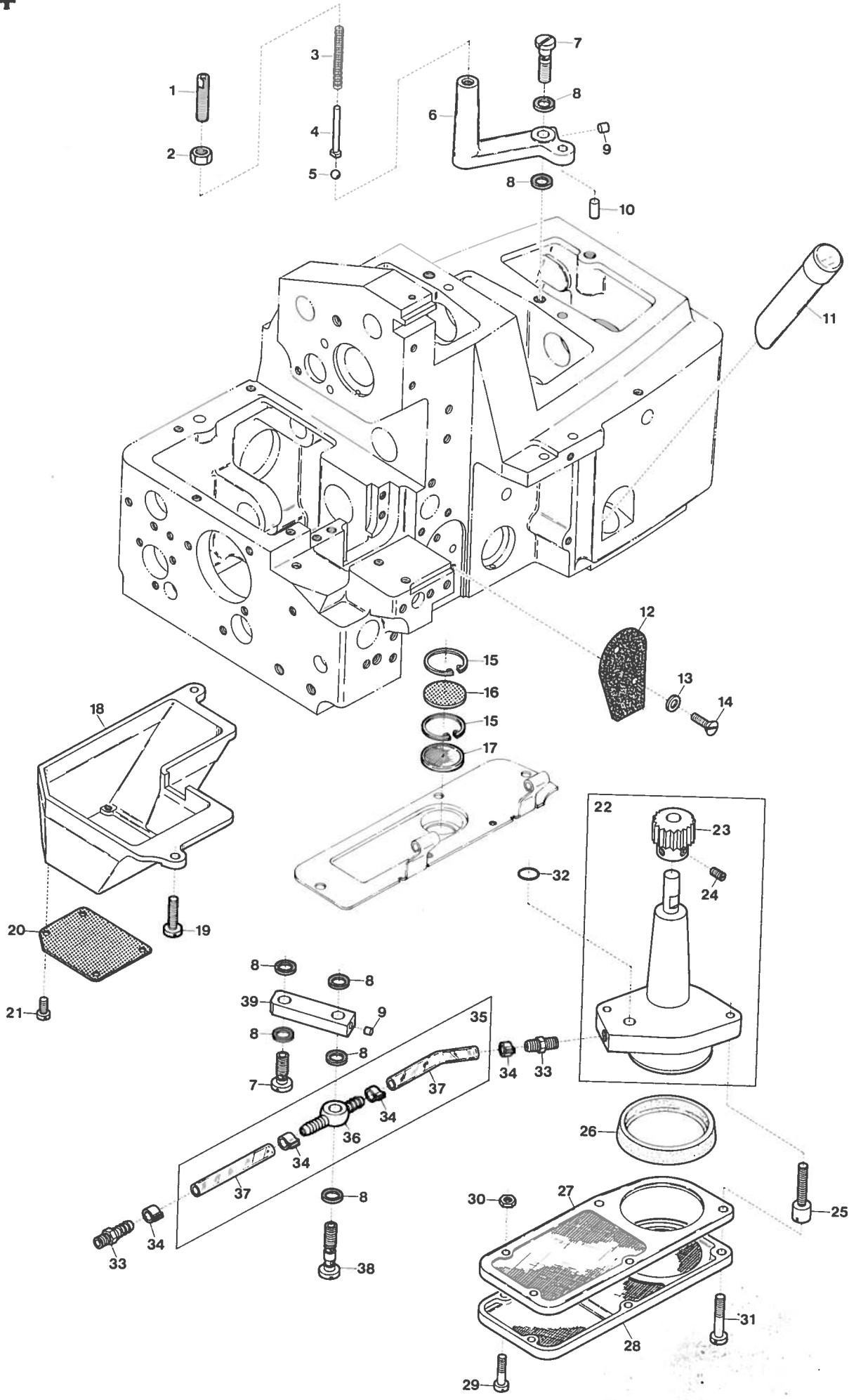

Ref. No.	Parts No.	Description	品名	Amt. Req.
1	20534	Oil Sight Nozzle	ノズル	1
2	419	Nut for 20534	ナット	1
3	30745	Oil Pressure Regulating Valve Spring	調圧弁バネ	1
4	30748	Oil Pressure Regulating Valve Spring Guide	調圧バネ案内ピン	1
5	80503	Oil Pressure Regulating Ball	調圧ボール弁	1
6	20535	Oil Pressure Regulating Valve	調圧弁座	1
7	4124	Oil Tube Fitting Stud (Short)	管継手ボルト(短)	2
8	567	Seal for 20535, 20540, 20539	パッキン	7
9	740	Seal Plug for 20535	詰栓	1
10	179	Pin for 20535	ピン	1
11	20533	Oil Sight Gauge	オイルゲージ	1
12	20325	Upper Looper Bar Oiling Felt	ルーパフェルト	1
13	538	Washer for 20325	ワッシャ	2
14	7619	Screw for 20325	ルーパフェルト止ネジ	2
15	20020	Filter Screen Clamp	前カバー濾過網押工	2
16	20019	Front Cover Filter Screen	前カバー濾過網	1
17	37680	Front Cover Filter Screen (Coarse Mesh)	前カバー濾過網(荒目)	1
18	20546	Feed Mechanism Filter Screen Frame	送り濾過網フレーム	1
19	9150	Screw for 20546	送り濾過網フレーム止ネジ	2
20	20547	Feed Mechanism Filter Screen	送り濾過網	1
21	4358	Screw for 20547	送り濾過網止ネジ	4
22	20526	Oil Pump, Complete Set	ポンプ(組)	1
23	20520	Worm Wheel	ウォームホイール	1
24	4108	Screw for 20520	ウォームホイール止ネジ	2
25	4115	Screw for 20526	ポンプ(組)止ネジ	2
26	20530	Pump Filter Screen Sleeve	ポンプ濾過網スリーブ	1
27	20531	Pump Filter Screen (Upper)	ポンプ濾過網(上)	1
28	20532	Pump Filter Screen (Lower)	ポンプ濾過網(下)	1
29	4116	Screw for 20531, 20532	ポンプ濾過網止ネジ	3
30	180	Nut for 20531, 20532	ナット	3
31	5004	Screw for Pump Filter Screen	ポンプ濾過網止ネジ	2
32	20538	O-Ring	Oリング	1
33	9909	Oil Tube Fitting Nut	パイプ継手	2
34	37675	Oil Tube Clamp	緊束環	4
35	20544	Oil Lubricating Tube, Complete Set	給油パイプ(組)	1
36	20540	Oil Tube Fitting Two Way	両口管継手	1
37	20542	Oil Tube	給油パイプ	1
38	4126	Oil Tube Fitting Stud (Long)	管継手ボルト(長)	1
39	20539	Lubricant Guiding Block	給油ブロック	1

Upper Knife (Angled Type) Assembly

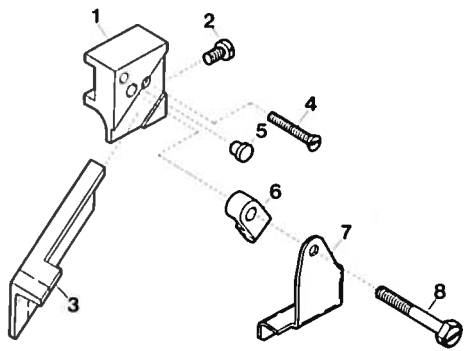

Z3000-C

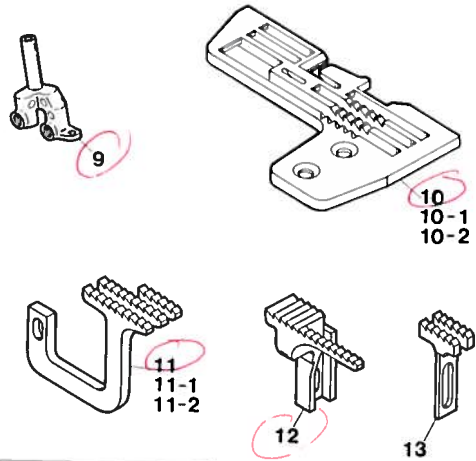

14
14-1
14-2

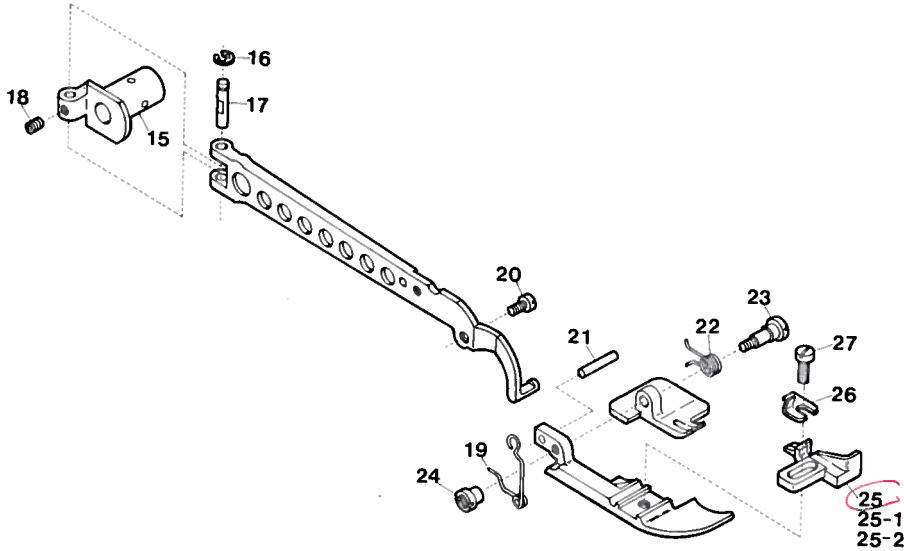

Z3002-A,C,Y

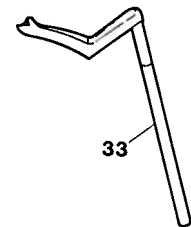

Z3000-Y

28
28-1

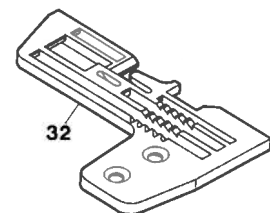
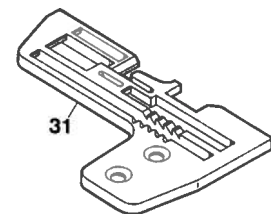
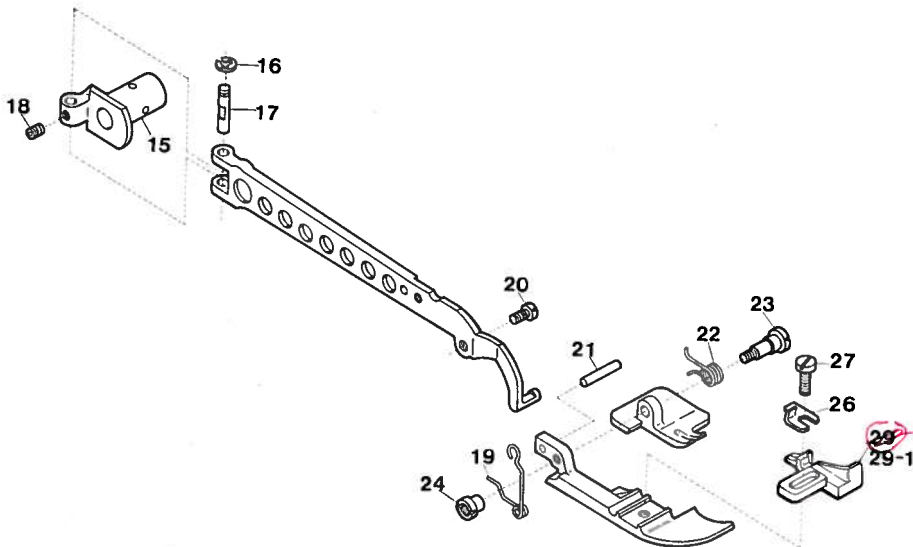

Ref. No.	Parts No.	Description	品名	Amt. Req.
1	20488	Upper Knife Holder (Angled Type)	上メスホルダ(角)	1
2	7616	Stopper Screw for 20491	上メスストップバネジ	1
3	20491	Upper Knife (Angled Type)	上メス(角)	1
4	4105	Screw for 20488	上メスホルダ止ネジ	1
5	20489	Upper Knife Holder (Angled) Packing Plug	上メスホルダ(角)埋メ座	1
6	20492	Upper Knife Clamp	上メス押工	1
7	20493	Upper Knife Chip Guard	切屑押シ	1
8	4104	Screw for 20493	切屑押シ止ネジ	1
9	20202	Needle Clamp	針止メ	1
10	20212	Stitch Plate (C5)	針板 C 5	1
10-1	20213	" " (C6)	針板 C 6	1
10-2	20214	" " (C7)	針板 C 7	1
11	20460	Differential Feed Dog (C5)	前送り C 5	1
11-1	20452	" " " (C6)	前送り C 6	1
11-2	20453	" " " (C7)	前送り C 7	1
12	20461	Main Feed Dog	後送り	1
13	20462	Auxiliary Feed Dog (for C7 only)	小送り C 7のみ	1
14	20264	Presser Foot, Complete Set (C5)	押工(組) C 5	1
14-1	20265	" " " " (C6)	押工(組) C 6	1
14-2	20266	" " " " (C7)	押工(組) C 7	1
15	20273	Presser Arm Hinge	押工腕ヒンジ	1
16	34293	Retaining Ring	E リング	1
17	20272	Presser Arm Hinge Pin	押工腕ヒンジピン	1
18	3637	Screw for 20272	押工腕ヒンジピン止ネジ	1
19	20254	Presser Foot Spring (Large)	押工バネ(大)	1
20	1222	Screw for 20254	押工バネ(大)止ネジ	1
21	731	Pin for 20255	押工バネ(小)止メピン	1
22	20255	Presser Foot Spring (Small)	押工バネ(小)	1
23	4128	Screw for 20255	押工バネ(小)止ネジ	1
24	216	Nut for 4128	ナット	1
25	20262	Presser Foot Stitch Tongue(5)	爪 5	1
25-1	20258	" " " " (6)	爪 6	1
25-2	20259	" " " " (7)	爪 7	1
26	20253	Presser Foot Hinge Spring	押工ヒンジバネ	1
27	4131	Screw for 20253	押工ヒンジバネ止ネジ	1
28	20267	Presser Foot, Complete Set (Y3)	押工(組) Y 3	1
28-1	20268	" " " " (Y4)	押工(組) Y 4	1
29	20257	Presser Foot Stitch Tongue(3)	爪 3	1
29-1	20256	" " " " (4)	爪 4	1
30	20201	Needle Clamp	針止メ	1
31	20207	Stitch Plate (Y3)	針板 Y 3	1
32	20208	" " (Y4)	針板 Y 4	1
33	20332	Upper Spreader	上スプレダ	1

"C2" DEVICE

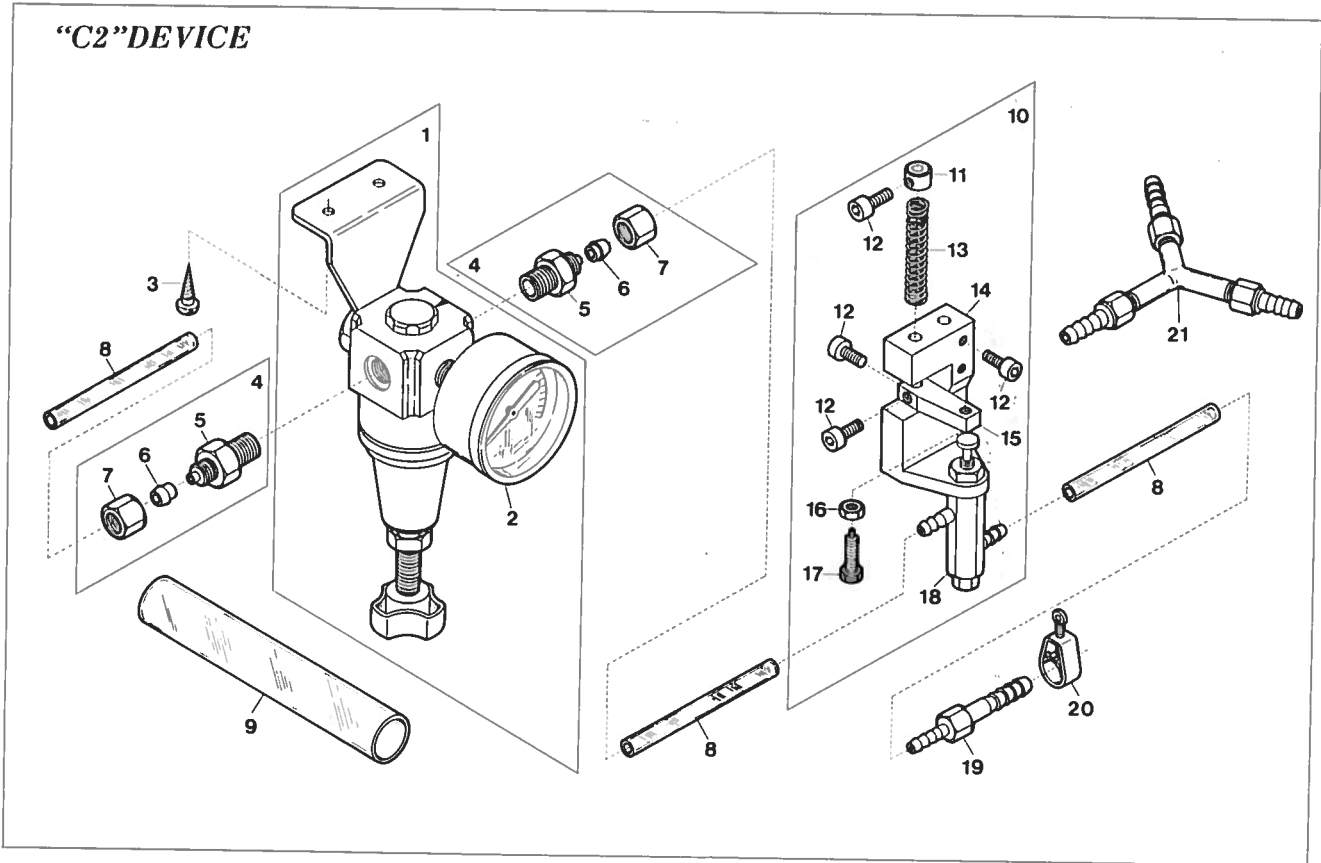

"K" DEVICE

22

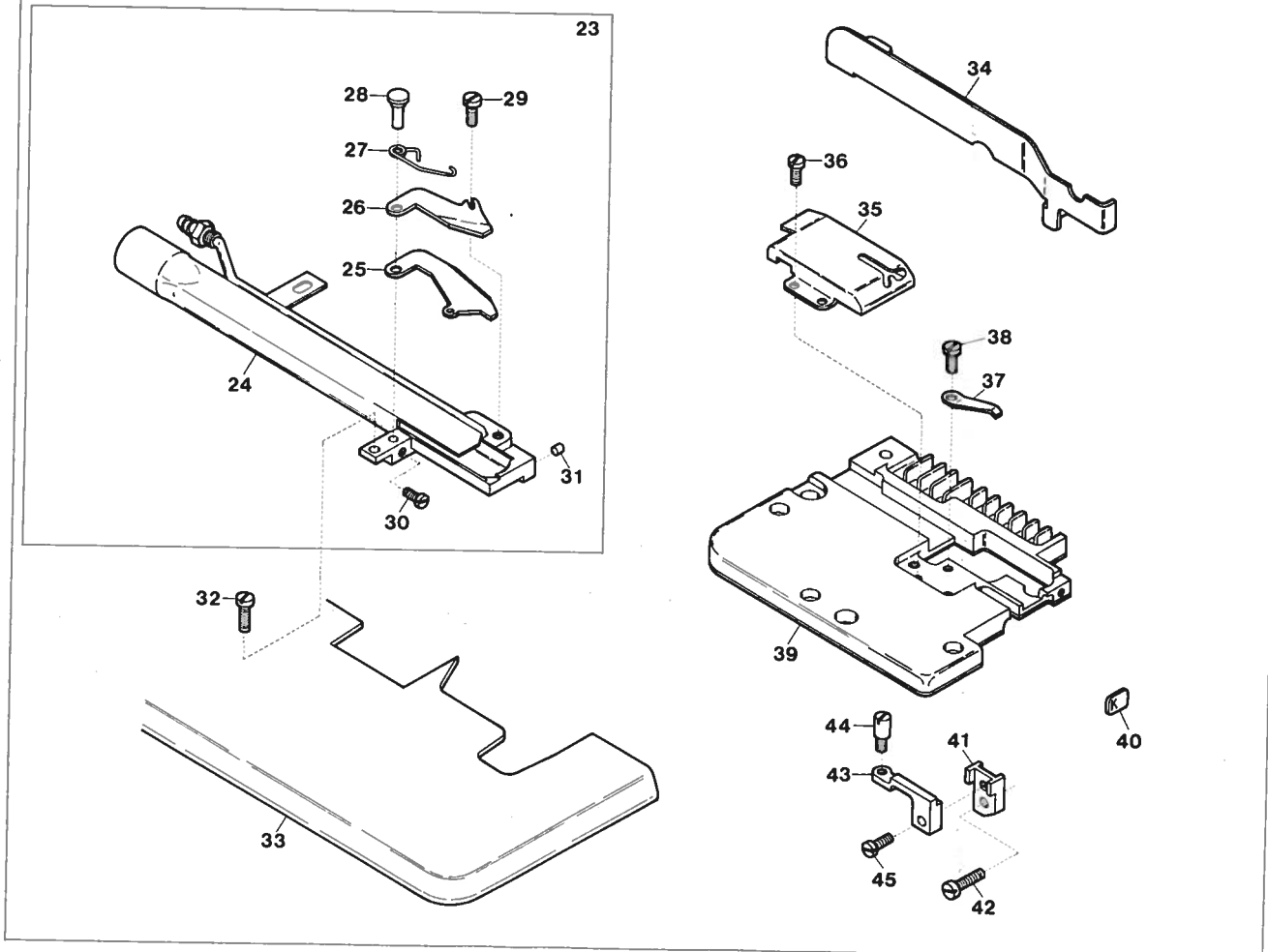

Ref. No.	Parts No.	Description	品名	Amt. Req.
1	33925	Regulator, Complete Set	レギュレータ(組)	1
2	33928	Pressure Gauge	プレッシャゲージ	1
3	6905	Screw for 33925	レギュレータ(組)止ネジ	2
4	33931	Mouth-Piece, PT $\frac{1}{8}$ inch, Complete Set	ストレートジョイント(組) $\frac{1}{8}$ インチ	2
5	33949	Mouth-Piece, PT $\frac{1}{8}$ inch	ストレートジョイント $\frac{1}{8}$ インチ	2
6	33951	Pipe Holder	ナイロンホルダ	2
7	33950	Nut for 33949	ナット	2
8	33941	Nylon Hose 4 ϕ	ナイロンホース 4 ϕ	3
9	33942	Nylon Hose 12 ϕ	ナイロンホース 12 ϕ	1
10	33953	Air Valve, Complete Set	エアバルブ(組)	1
11	33938	Collar for 33937	エアバルブ補助バネカラー	1
12	5040	Screw for 33938, 33936, 33935	止ネジ	5
13	33937	Return Spring for Air Valve Stopper	エアバルブ補助バネ	1
14	33936	Air Valve Holder	エアバルブ取付台	1
15	33935	Air Valve Stopper	エアバルブストッパ	1
16	334	Nut for 33935	ナット	1
17	5505	Screw for 33935	調節ネジ	1
18	33934	Air Valve	エアバルブ	1
19	33932	Joint, for Single Head	ジョイント(ミシンが1台の時のみ使用)	1
20	33939	Hose Band, $\frac{1}{4}$ inch	ホースバンド $\frac{1}{4}$ インチ	3
21	33933	Three Pronged Joint, for Plural Heads	三又ジョイント(ミシンが2台以上の時使用)	1
22	20932	"K" Device, Complete Set	"K"装置(組)	1
23	20933	Suction Pipe, Complete Set	吸込管(組)	1
24	20931	Suction Pipe	吸込管本体	1
25	33574	Lower Trimming Knife	下刃	1
26	33590	Upper Trimming Knife	上刃	1
27	33575	Lower Trimming Knife Spring	下刃バネ	1
28	33588	Trimming Knife Holder Pin	刃支持ピン	1
29	5036	Screw for 33590	上刃止ネジ	1
30	1230	Screw for 33588	刃支持ピン止ネジ	1
31	720	Packing Piece for 20931	詰栓	1
32	1202	Screw for 20931	吸込管本体止ネジ	1
33	20923	Cloth Plate	クロスプレート	1
34	20924	Cloth Plate Fabric Guide	クロスプレート布案内	1
35	33592	Suction Pipe Cover	吸込管カバー	1
36	4358	Screw for 33592	吸込管カバー止ネジ	2
37	33593	Lower Trimming Knife Pushing Plate	下刃圧着バネ	1
38	7618	Screw for 33593	下刃圧着バネ止ネジ	1
39	20921	Feed Mechanism Cover	送り台カバー	1
40	20902	Device Indicate Plate for "K"	デバイス記号板	1
41	33581	Guide Holder Connection for Lower Trimming Knife	下刃ガイド取付台	1
42	7609	Screw for 33581	下刃ガイド取付台止ネジ	1
43	20928	Guide Holder for Lower Trimming Knife	下刃ガイドピン取付台	1
44	3348	Guide Pin for Lower Trimming Knife	下刃ガイドピンネジ	1
45	1196	Screw for 20928	下刃ガイドピン取付台止ネジ	1

"MT" DEVICE

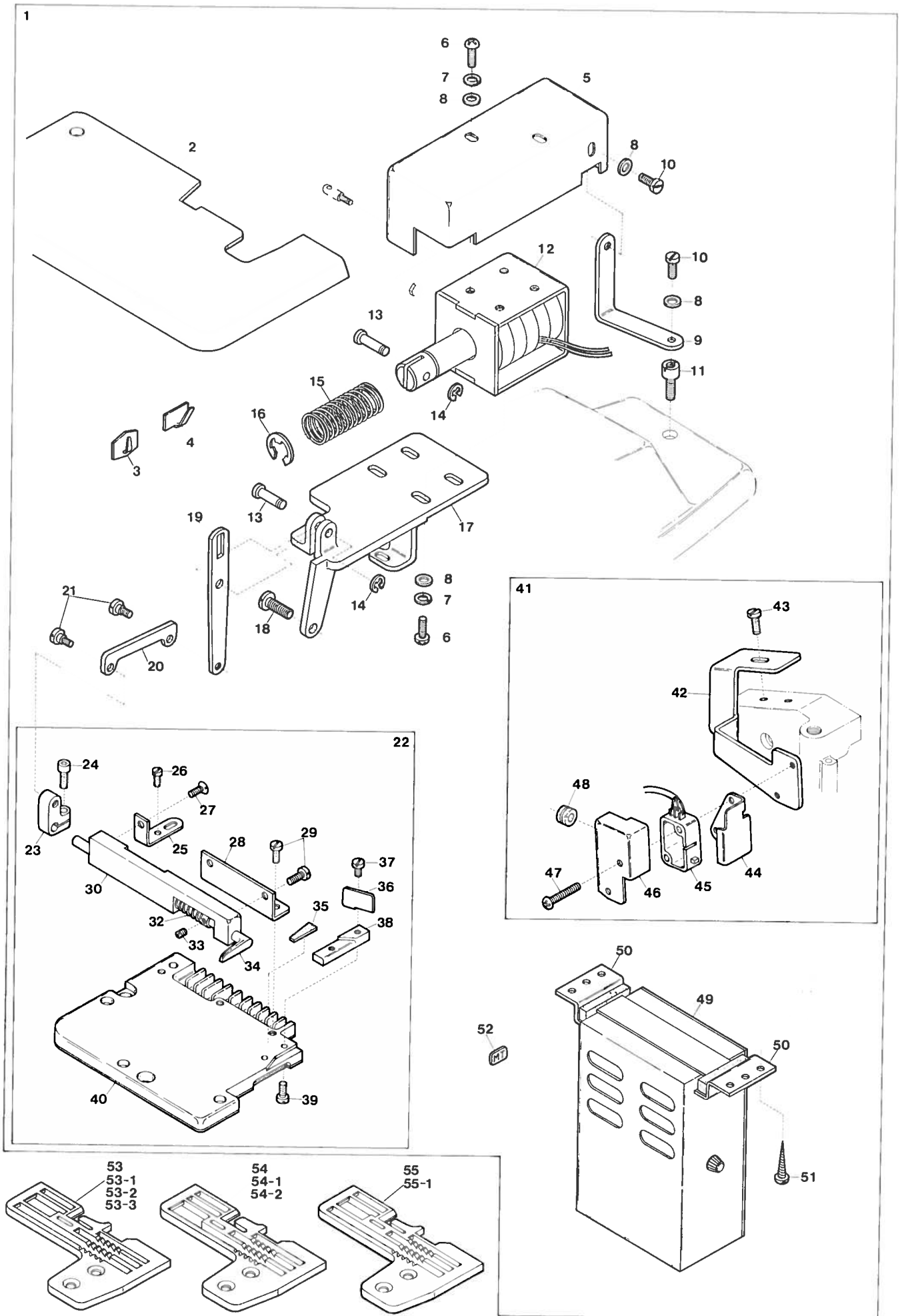

Ref. No.	Parts No.	Description	品名	Amt. Req.
1	20960	“MT” Device, Complete Set	“MT”装置(組)	1
2	20973	Cloth Plate	クロスプレート	1
3	35766	Cord Clamp (Medium)	コード支工(中)	2
4	35767	Cord Clamp (Large)	コード支工(大)	1
5	20985	Solenoid Cover	ソレノイドカバー	1
6	9992	Screw for 20985, 11760	止ネジ	6
7	644	Spring Washer for 20985, 11760	スプリングワッシャ	6
8	538	Washer for 20985, 20986, 11760	ワッシャ	8
9	20986	Anti-Vibration Plate for Solenoid Cover	ソレノイド振れ止め板	1
10	1202	Screw for 20986	ソレノイド振れ止め板止ネジ	2
11	4132	Screw for Top Cover	上カバー止ネジ	1
12	11760	Solenoid	ソレノイド	1
13	35301	Solenoid Connecting Rod Pin	連結棒ピン	2
14	33024	Retaining Ring for 35301	“E”リング	2
15	35297	Solenoid Spring	ソレノイドバネ	1
16	35300	Retaining Ring for 35297	ソレノイドバネストップリング	1
17	20981	Solenoid Supporter	ソレノイド取付板	1
18	4635	Screw for 20981	ソレノイド取付板止ネジ	1
19	20982	Solenoid Connecting Lever	ソレノイドレバー	1
20	35302	Upper Knife Connecting Plate	上メス連結板	1
21	6068	Screw for 35302	上メス連結板止ネジ	2
22	20980	Trimming Device, Complete Set	メス装置(組)	1
23	35296	Upper Knife Driving Lever	上メス腕	1
24	5098	Screw for 35296	上メス腕止ネジ	1
25	20978	Upper Knife Holder Stay (Rear)	上メス支工(後)	1
26	1208	Screw for 20978	上メス支工(後)止ネジ	1
27	7621	Screw for 20978	上メス支工(後)止ネジ	1
28	33695	Upper Knife Holder Stay (Front)	上メス支工(前)	1
29	4351	Screw for 33695	上メス支工(前)止ネジ	4
30	20977	Upper Knife Holder	上メス台	1
31	33711	Upper Knife Spring	上メスバネ	1
32	33710	Upper Knife Spring Collar	上メスカラー	1
33	3637	Screw for 33710	上メスカラー止ネジ	1
34	20976	Upper Knife	上メス	1
35	35314	Rubber Cushion for Upper Knife	上メスクッション	1
36	20974	Fabric Guide	布案内	1
37	4236	Screw for 20974	布案内止ネジ	1
38	20979	Lower Knife	下メス	1
39	4404	Screw for 20979	下メス止ネジ	2
40	20971	Feed Mechanism Cover	送り台カバー	1
41	11753	Manual Switch, Complete Set	スイッチ(組)	1
42	20987	Switch Supporter	スイッチ取付板	1
43	4440	Screw for 20987	スイッチ取付板止ネジ	1
44	35721	Manual Switch Plate	スイッチ板	1
45	11754	Switch	スイッチ	1
46	35720	Switch Cover	スイッチカバー	1
47	9993	Screw for 35720	スイッチカバー止ネジ	2
48	35722	Cord Bushing	コードブッシュ	1
49	11764	Control Box, Complete Set	MT制御装置(組)	1
50	11709	Control Box Stay	コントロールボックスステー	2
51		Wood Screw for 11709	木ネジ	4
52	20903	Device Indicate Plate for “MT”	デバイス記号板	1
53	20961	Stitch Plate (A3)	針板(A3)	1
53-1	20962	“ ” (A4)	“ ” (A4)	1
53-2	20963	“ ” (A5)	“ ” (A5)	1
53-3	20964	“ ” (A6)	“ ” (A6)	1
54	20965	Stitch Plate (C5)	針板(C5)	1
54-1	20966	“ ” (C6)	“ ” (C6)	1
54-2	20967	“ ” (C7)	“ ” (C7)	1
55	20968	Stitch Plate (Y3)	針板(Y3)	1
55-1	20969	“ ” (Y4)	“ ” (Y4)	1

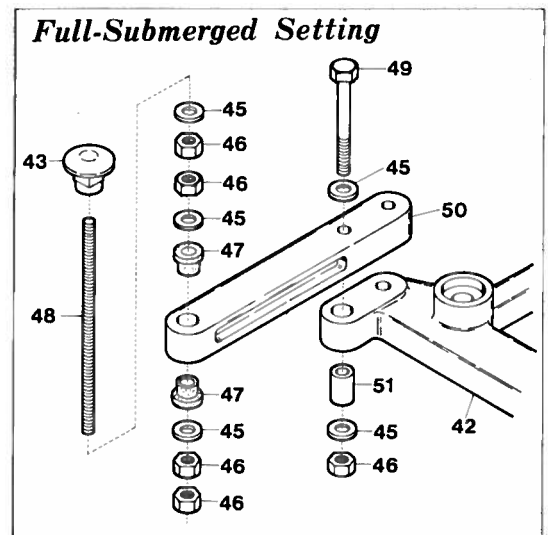
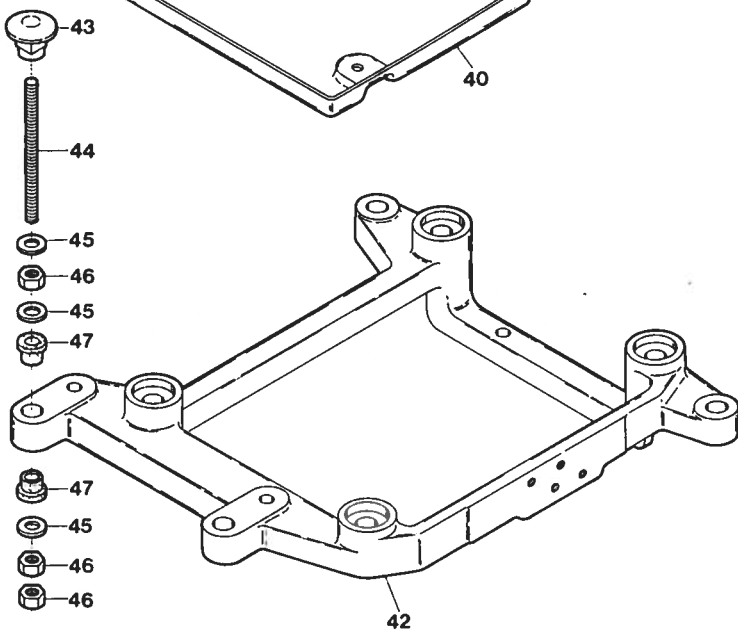
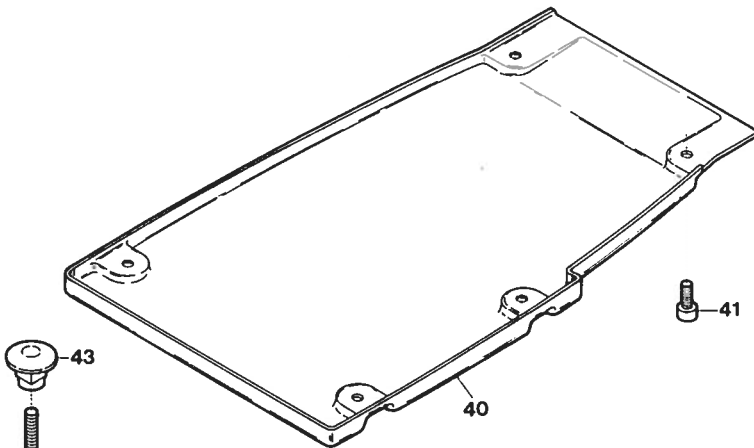
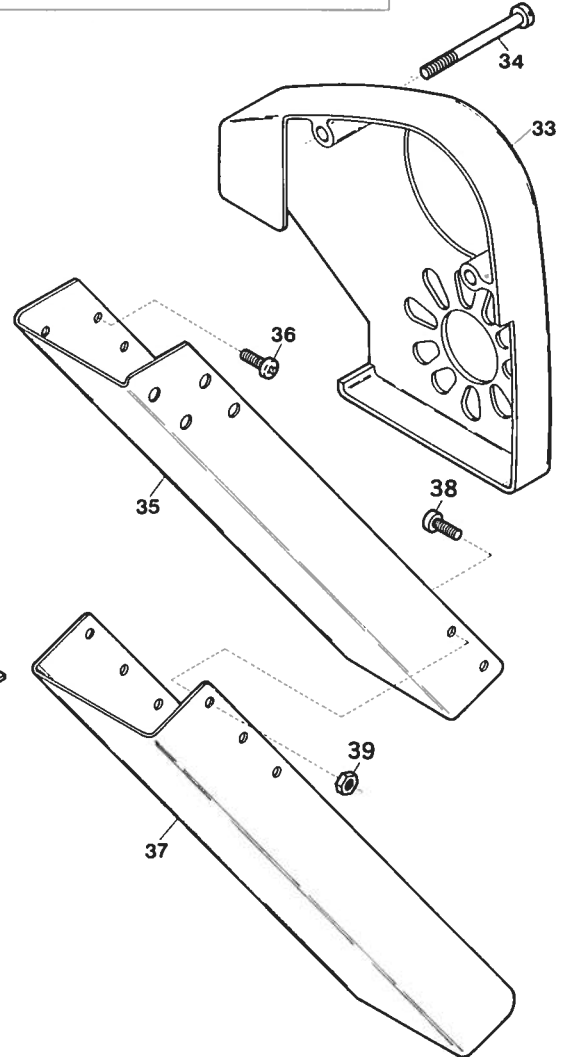
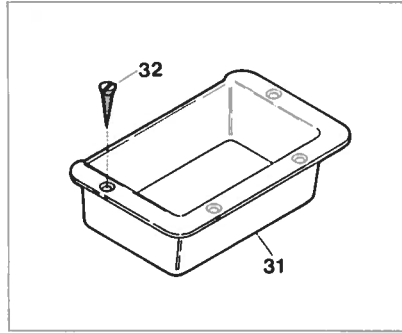
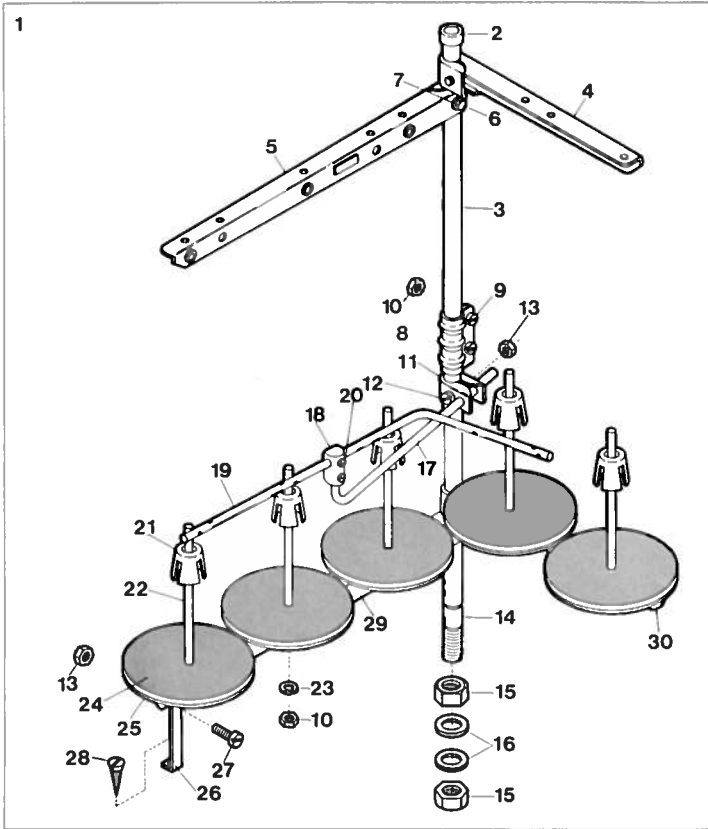

Ref. No.	Parts No.	Description	品名	Amt. Req.
1	99056	Thread Stand, Complete Set (5 Spools Type)	糸立台(組) (5本糸用)	1
2	99057	Column Cap	コラムキャップ	1
3	99058	Column Pipe (Upper)	コラムパイプ(上)	1
4	99059	Thread Hanger (2 Spools Type)	スレッドハンガ(2本糸用)	1
5	99060	Thread Hanger (3 Spools Type)	スレッドハンガ(3本糸用)	1
6	147	Screw for 99059, 99060	止ネジ	4
7	148	Washer for 99059, 99060	ワッシャ	4
8	99061	Column Pipe Connector	コラムパイプ継手	1
9	149	Screw for 99061	止ネジ	2
10	150	Nut for 99061, 99066	ナット	7
11	99062	Thread Guide Holder	糸案内ホルダ	1
12	151	Screw for 99062	止ネジ	1
13	152	Nut for 99062, 99069	ナット	2
14	99063	Column Pipe (Lower)	コラムパイプ(下)	1
15	153	Nut for 99063	ナット	2
16	154	Washer for 99063	ワッシャ	2
17	99030	Thread Guide Bar	糸案内支工棒	1
18	99031	Thread Guide Bar Bracket	支工棒接点	1
19	99064	Thread Guide	糸案内	1
20	156	Screw for 99064	止ネジ	2
21	99065	Spool Cushion	スプールクッション	5
22	99066	Spool Pin	スプール軸	5
23	157	Spring Washer for 99066	スプリングワッシャ	5
24	99067	Spool Mat	スプールマット	5
25	99068	Spool Seat Disc	受ケ皿	5
26	99069	Spool Holder Stay	スプールホルダ支工	1
27	158	Screw for 99069	止ネジ	1
28	159	Wood Screw for 99069	木ネジ	1
29	99070	Spool Holder (3 Spools Type)	スプールホルダ(3本糸用)	1
30	99071	Spool Holder (2 Spools Type)	スプールホルダ(2本糸用)	1
31	30080	Chip Receiver (Semi-submerged only)	切屑受ケ(半沈式のみ)	1
32	—	Wood Screw for 30080	木ネジ	4
33	20039	Belt Cover	ベルトカバー	1
34	4102	Screw for 20039	ベルトカバー止ネジ	2
35	20068	Chute (Upper)	シュート(上)	1
36	9992	Screw for 20068	シュート(上)止ネジ	2
37	20069	Chute (Lower)	シュート(下)	1
38	4127	Screw for 20069	シュート(下)止ネジ	4
39	15	Nut for 20069	ナット	4
40	20059	Wind Guide Plate	送風案内板	1
41	5037	Screw for 20059	送風案内板止ネジ	5
42	20058	Supporting Board	受ケ板	1
43	160	Hanging Nut for 20058	吊リナット	4
44	164	Hanging Bolt for 20058 (Semi-submerged only)	吊リボルト(半沈式のみ)	4
45	162	Washer for 20058 (Semi-submerged)	ワッシャ(半沈式)	12
45-1	162	Washer for 20058 (Full-submerged)	ワッシャ(全沈式)	20
46	161	Nut for 20058 (Semi-submerged)	ナット(半沈式)	12
46-1	161	Nut for 20058 (Full-submerged)	ナット(全沈式)	20
47	20064	Supporting Board Rubber Cushion	受ケ板ゴム座	8
48	163	Hanging Bolt for 20058 (Full-submerged only)	吊リボルト(全沈式のみ)	4
49	165	Bolt for 20057 ()	ボルト(全沈式のみ)	4
50	20057	Supporting Board Connector ()	受ケ板支工具(全沈式のみ)	2
51	20045	Supporting Board Sleeve ()	受ケ板スリーブ(全沈式のみ)	2

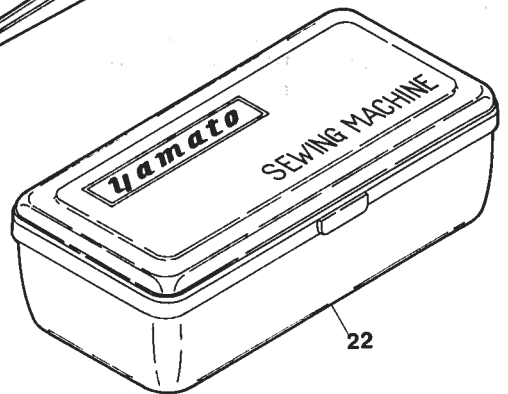
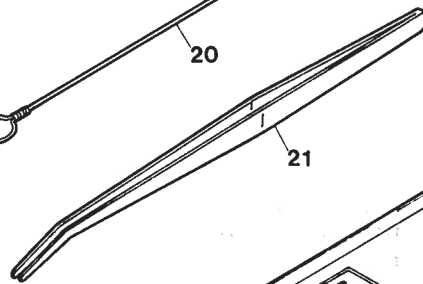
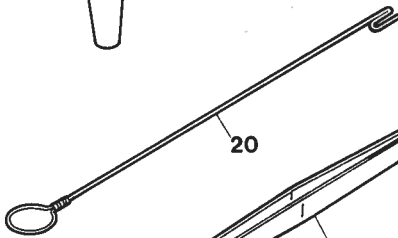
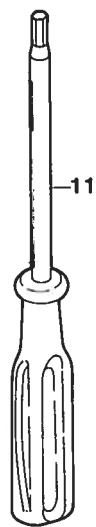
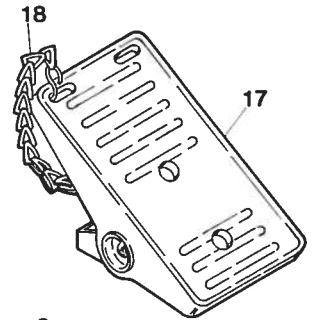
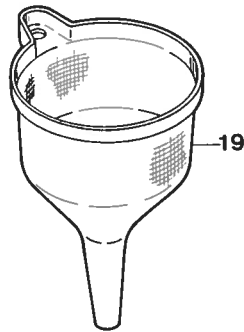
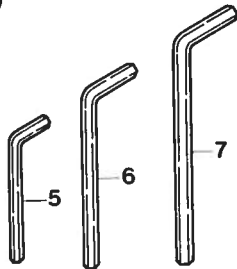
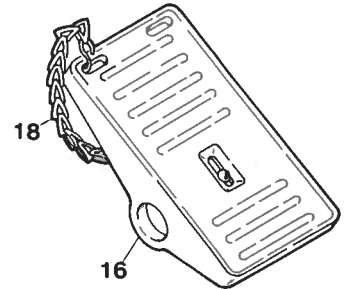
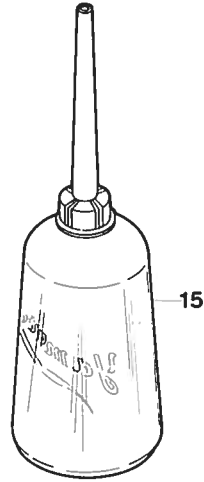
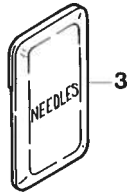
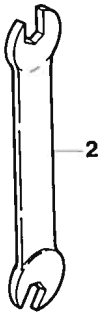
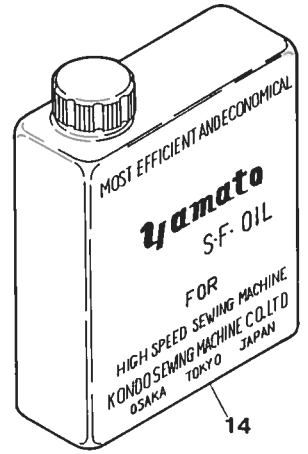
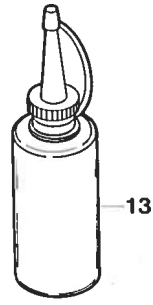
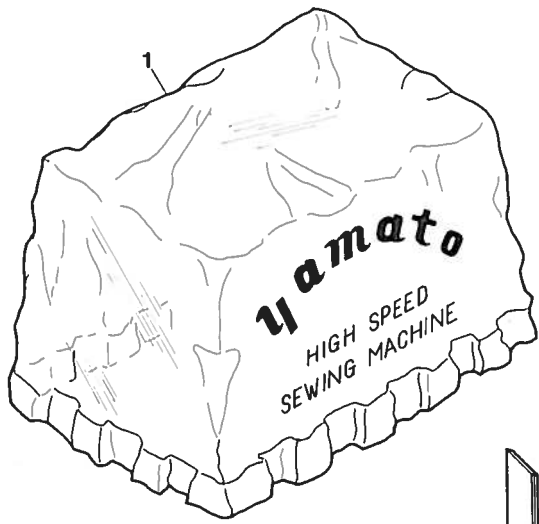

Ref. No.	Parts No.	Description	品名	Amt. Req.
1	37939	Machine Cover	ビニールカバー	1
2	37945	Wrench (7.14×7.94mm) ($\frac{9}{32} \times \frac{5}{16}$ inch)	両口スパナ (7.14×7.94ミリ) ($\frac{9}{32} \times \frac{5}{16}$ インチ)	1
3	—	Needle	針 (D C × 27)	10
4	20498	Lower Knife	下メス	1
5	37916	Hexagon Wrench Key (3.18mm) ($\frac{1}{8}$ inch)	キーレンチ (3.18ミリ) ($\frac{1}{8}$ インチ)	1
6	85964	Hexagon Wrench Key (3.97mm) ($\frac{5}{32}$ inch)	キーレンチ (3.97ミリ) ($\frac{5}{32}$ インチ)	1
7	37922	Hexagon Wrench Key (4.76mm) ($\frac{3}{16}$ inch)	キーレンチ (4.76ミリ) ($\frac{3}{16}$ インチ)	1
8	37901	Screw Driver (Large)	ドライバ (大)	1
9	37902	Screw Driver (Medium)	ドライバ (中)	1
10	37903	Screw Driver (Small)	ドライバ (小)	1
11	37923	Hexagon Screw Driver (1.98mm) ($\frac{5}{64}$ inch)	キーレンチ付ドライバ (1.98ミリ) ($\frac{5}{64}$ インチ)	1
12	37919	Hexagon Screw Driver (1.58mm) ($\frac{1}{16}$ inch)	キーレンチ付ドライバ (1.58ミリ) ($\frac{1}{16}$ インチ)	1
13	99043	Silicone Oil	シリコンオイル	1
14	—	Oil (1 Litre)	オイル (1ℓ)	1
15	37932	Oiler	油差シ	1
16	37911	Pedal, Complete Set, for Domestic Sale Only	ペダル (組) (国内向のみ)	1
17	37907	Pedal, Complete Set, for Export Only	ペダル (組) (輸出向のみ)	1
18	37912	Chain	鎖	1
19	37943	Funnel	ジョウゴ	1
20	93550	Thread Hook	スレッドフック	1
21	99051	Thread Tweezers	ピンセット	1
22	37913	Tool Box	工具箱	1
23	3637	Screw for Needle	針止ネジ	2

List of Main Spare Parts

Main Parts Models	Needle Clamp	Presser Foot Complete Set	Stitch Tongue	Stitch Plate	Differential Feed Dog	Main Feed Dog	Auxiliary Feed Dog	Upper Looper	Lower Looper	Double Chaining Looper	Needle Guard (Double Chain Stitch)		Needle Guard (Overlock Stitch)	
	針止メ	押エ(組)	押エの爪	針板	前送り	後送り	小送り	上ループ	下ループ	二重ループ	インタ針授(前)	インタ針授(後)	フロント	リア
Z3000-A3DF	20200	20294	20257	20209 (20961)	20451	20440	20441	20324 (20332)	20347	20378	20226	20227	20223	20224
" A3DA														
Z3000-A4DF	20200	20291	20256	20210 (20962)	20439	20440	20441	20324 (20332)	20347	20378	20226	20227	20223	20224
" A4DA														
Z3000-A5DF	20200	20295	20262	20211 (20963)	20460	20440	20441	20324 (20332)	20347	20378	20226	20227	20223	20224
" A5DA														
Z3000-A6DF	20200	20296	20258	20215 (20964)	20452	20440	20441	20324 (20332)	20347	20378	20226	20227	20223	20224
" A6DA														
Z3000-C5DF	20202	20264	20262	20212 (20965)	20460	20461	20441	20324 (20332)	20347	20378	20226	20227	20223	20224
" C5DA														
Z3000-C6DF	20202	20265	20258	20213 (20966)	20452	20461	20441	20324 (20332)	20347	20378	20226	20227	20223	20224
" C6DA														
Z3000-C7DF	20202	20266	20259	20214 (20967)	20453	20461	20462	20324 (20332)	20347	20378	20226	20227	20223	20224
" C7DA														
Z3000-Y3DF	20201	20267	20257	20207 (20968)	20451	20440	20441	20324 (20332)	20347	20378	20226	20227	20223	20224
" Y3DA														
Z3000-Y4DF	20201	20268	20256	20208 (20969)	20439	20440	20441	20324 (20332)	20347	20378	20226	20227	20223	20224
" Y4DA														

Note:1) () in "Stitch Plate" -indicating the same in case of "with MT Device".
針板の () はMT装置付の場合。

2) () in "Upper Looper" -indicating "Upper Spreader" in case of Z3002, 4 threads.
上ループの () 内はZ3002(4本糸)の場合は上スプレダを表わす。

Z 3000

INDEX

Parts No.	Page No.	Ref. No.	Weight (g)
15	18	39	0.7
147	18	6	4
148	18	7	0.5
149	18	9	1.5
150	18	10	0.8
151	18	12	4.5
152	18	13	1.5
153	18	15	1
154	18	16	5
156	18	20	1
157	18	23	0.7
158	18	27	2
159	18	28	3
160	18	43	18.5
161	18	46	5.5
162	18	45	3
163	18	48	51
164	18	44	27
165	18	49	21.5
178	4	6	0.3
179	14	10	1.8
180	14	30	0.2
181	12	51	13
182	4	28	4.3
183	6	16	4.4
184	1	35	3.2
185	12	47	2.7
186	12	49	1
187	7	4	0.03
188	3	8	0.1
189	7	9	0.03
190	7	12	0.06
191	12	22	0.4
192	12	32	0.5
193	12	12	0.3
194	6	18	0.2
195	6	25	0.2
197	11	40	0.04
199	6	31	0.02
216	9	38	0.3
216	15	24	0.3
278	10	16	0.03
304	10	21	0.14
322	1	17	0.3
331	3	18	0.7
334	9	19	0.6
334	16	16	0.6
335	1	12	0.8
340	4	11	0.5
340	12	53	0.5
419	14	2	1
447	10	29	0.1

Parts No.	Page No.	Ref. No.	Weight (g)
451	12	14	1.5
461	9	2	8.5
520	6	8	0.3
520	8	7	0.3
520	10	13	0.3
520	11	18	0.3
520	12	7	0.3
532	1	9	0.3
532	4	47	0.3
538	14	13	0.4
538	17	8	0.4
541	4	25	0.35
542	11	42	0.3
550	3	29	0.03
567	6	7	0.07
567	8	8	0.07
567	11	19	0.07
567	12	8	0.07
567	14	8	0.07
644	17	7	0.8
687	12	20	0.1
720	6	32	0.02
720	11	7	0.02
720	16	31	0.02
726	2	21	0.06
726	3	19	0.06
730	11	37	0.06
730	12	30	0.06
731	9	35	0.7
731	15	21	0.7
740	10	9	0.1
740	11	14	0.1
740	14	9	0.1
750	6	11	0.3
750	8	12	0.3
750	12	23	0.3
755	6	26	0.2
755	12	13	0.2
800	2	41	1
801	2	42	0.6
976	2	20	0.9
1132	1	18	1.3
1170	5	15	0.1
1186	1	13	1
1196	2	15	0.5
1196	16	45	0.5
1202	16	32	0.8
1202	17	10	0.8
1208	7	17	0.6
1208	10	25	0.6

Parts No.	Page No.	Ref. No.	Weight (g)
1208	11	44	0.6
1208	17	26	0.6
1222	9	34	0.5
1222	15	20	0.5
1228	2	35	0.2
1230	16	30	0.2
1326	4	37	1
1326	11	23	1
1330	2	23	0.6
1330	4	48	0.6
1457	6	39	2.3
1459	6	33	0.1
1732	3	2	1
1733	4	35	1
3313	10	17	0.1
3348	16	44	1
3405	13	19	1
3410	11	33	0.35
3434	1	6	0.4
3434	3	41	0.4
3434	5	13	0.4
3434	6	23	0.4
3436	13	20	0.6
3632	2	2	1.7
3632	5	26	1.7
3632	7	19	1.7
3632	9	27	1.7
3632	13	2	1.7
3635	13	8	0.9
3637	2	40	0.1
3637	6	41	0.1
3637	9	5	0.1
3637	13	24	0.1
3637	15	18	0.1
3637	17	33	0.1
3637	19	23	0.1
3638	5	10	0.5
3638	6	35	0.5
3638	7	14	0.5
3638	8	28	0.5
3638	10	33	0.5
3638	11	21	0.5
3638	13	31	0.5
3646	1	24	0.9
3646	12	10	0.9
3654	5	16	3.5
4100	12	36	3
4101	2	13	3.4
4102	18	34	9.7
4103	9	16	13.5
4104	15	8	1.8
4105	15	4	0.3
4106	8	20	1.1

INDEX

Parts No.	Page No.	Ref. No.	Weight (g)	Parts No.	Page No.	Ref. No.	Weight (g)	Parts No.	Page No.	Ref. No.	Weight (g)
4107	9	14	3	4440	2	38	1.5	7405	8	18	1.2
4108	5	6	0.4	4440	4	26	1.5	7609	13	10	1
4108	14	24	0.4	4440	7	13	1.5	7609	16	42	1
4109	9	12	0.4	4440	8	30	1.5	7616	15	2	0.3
4109	13	29	0.4	4440	13	33	1.5	7618	16	38	0.5
4110	12	44	4.6	4440	17	43	1.5	7619	14	14	0.4
4111	12	52	4	4441	3	10	2.2	7621	17	27	0.5
4112	13	28	0.3	4591	8	25	2.4	7678	3	7	3.2
4113	11	36	6	4635	3	16	4	7904	4	8	5.0
4114	4	23	1.3	4635	17	18	4	9121	2	33	0.6
4115	14	25	6.7	5000	9	10	0.5	9127	9	18	1.1
4116	14	29	1	5004	14	31	2.3	9143	1	8	0.4
4117	1	16	4.5	5036	16	29	0.6	9150	6	45	2
4118	12	43	0.6	5037	18	41	2.1	9150	14	19	2
4119	9	1	27	5038	12	50	2	9508	6	4	1
4120	4	32	3	5040	11	26	2	9508	8	4	1
4121	10	3	1.6	5040	16	12	2	9508	10	23	1
4121	11	3	1.6	5070	6	2	5	9533	2	31	0.6
4122	2	12	8.3	5070	8	2	5	9604	1	20	0.9
4123	5	2	1.5	5070	10	2	5	9604	6	10	0.9
4124	14	7	4	5070	11	2	5	9604	13	16	0.9
4125	4	9	5	5076	1	26	8	9624	12	28	0.4
4126	14	38	5.3	5083	2	4	4	9730	13	4	0.6
4127	18	38	0.8	5094	3	32	1.7	9853	4	19	1.6
4128	9	37	1	5098	7	20	1.5	9853	13	35	1.6
4128	15	23	1	5098	17	24	1.5	9909	14	33	2
4129	8	10	2.5	5108	1	34	6	9930	12	46	6
4129	12	2	2.5	5108	6	17	6	9931	3	37	2.8
4131	9	41	0.6	5108	10	7	6	9932	3	28	1
4131	15	27	0.6	5108	11	12	6	9992	17	6	2
4132	17	11	0.8	5112	2	25	0.3	9992	18	36	2
4236	9	43	0.34	5345	2	10	0.9	9993	17	47	2.5
4236	17	37	0.34	5345	3	5	0.9	10017	7	5	1.6
4314	3	11	0.4	5345	6	43	0.9	11709	17	50	48
4320	4	40	0.8	5500	11	17	5	11753	17	41	84
4351	10	5	0.9	5505	9	20	2.1	11754	17	45	5
4351	11	5	0.9	5505	16	17	2.1	11760	17	12	890
4351	17	29	0.9	5512	12	35	1	11764	17	49	3kg
4353	4	17	0.9	5520	6	6	5	20000	1	37	11.9kg
4353	8	15	0.9	5520	8	6	5	20001	2	3	625
4353	13	13	0.9	5520	12	6	5	20002	2	6	7
4358	1	3	0.9	5520	10	14	4	20003	2	5	12
4358	4	42	0.9	5550	9	24	3	20004	2	7	8
4358	10	27	0.9	5550	11	29	3	20005	2	8	1.2
4358	14	21	0.9	5550	12	38	3	20006	2	11	470
4358	16	36	0.9	5650	11	10	3	20007	2	18	50
4401	6	27	0.3	6068	17	21	2.5	20008	2	19	4.2
4404	7	24	0.2	6405	9	8	0.6	20009	2	29	
4404	17	39	0.2	6816	1	33	6.5	20010	2	43	1.7
4406	3	27	1.3	6905	16	3	2	20014	2	32	0.3
4437	3	13	1.5	7006	1	11	0.7	20015	2	37	125
4437	10	31	1.5	7128	6	37	0.8	20016	2	39	11.5
4437	11	8	1.5								
4438	3	34	1.4								
4440	1	29	1.5								

INDEX

Parts No.	Page No.	Ref. No.	Weight (g)
20017	2	44	1
20018	2	36	1.3
20019	14	16	0.8
20020	14	15	0.8
20021	3	33	27
20022	3	39	30
20024	2	34	14
20030	1	1	360
20032	1	4	9
20034	1	2	292
20035	1	7	10
20036	1	14	10
20037	1	5	0.6
20038	1	15	1.6
20039	18	33	88
20040	3	15	53
20042	3	12	152
20043	3	9	19
20045	18	51	9.3
20046	3	21	4
20047	3	20	13.5
20048	1	30	1410
20049	1	31	70
20050	1	36	19
20051	3	23	1
20052	3	22	1.7
20053	1	32	12
20054	1	21	80
20056	1	23	20
20057	18	50	246
20058	18	42	1kg
20059	18	40	72
20060	3	4	23
20061	3	6	3.6
20062	2	28	2
20063	2	24	2
20064	18	47	2.4
20065	2	30	0.2
20066	2	27	1.1
20067	2	26	7
20068	18	35	363
20069	18	37	414
20072	3	14	0.6
20100	4	10	24
20101	4	14	8
20102	4	12	2.7
20103	4	13	2
20104	4	1	8
20105	4	1	80
20106	4	15	2
20107	4	43	49
20108	4	46	1.1
20109	4	44	1
20110	4	45	0.7

Pasts No.	Page No.	Ref. No.	Weight (g)
20111	11	22	10
20112	10	26	6
20113	4	16	3
20114	4	50	2.7
20115	4	20	0.3
20116	4	21	0.3
20117	8	14	5
20118	4	5	1.1
20119	4	27	9
20120	4	38	5
20121	4	39	2
20122	4	34	19
20123	4	33	6.8
20124	4	31	1.7
20125	4	30	0.4
20126	4	29	1.5
20127	5	9	28
20128	4	18	4
20129	4	49	1.3
20130	2	9	15
20131	4	22	0.2
20132	4	3	2
20150	5	7	468
20151	5	11	12
20152	5	1	144
20154	5	3	62
20155	5	5	42
20156	5	12	174
20157	5	14	94
20158	5	17	64
20159	5	8	53
20160	3	26	82
20161	3	25	0.1
20162	3	1	35
20163	3	3	30
20180	6	1	48
20181	6	3	5.5
20181	8	3	5.5
20182	6	5	27
20184	6	12	85
20185	5	22	30
20186	5	23	45
20187	5	24	0.8
20188	6	29	25
20189	6	21	3
20190	6	36	2
20191	6	24	5
20192	6	20	40
20193	5	22	15
20194	6	25	13
20195	6	30	2.6
20198	6	14	32
20199	6	15	24

Parts No.	Page No.	Ref. No.	Weight (g)
20200	6	38	3
20201	15	30	3
20202	15	9	3
20207	15	31	27
20208	15	32	27
20209	6	42-3	27
20210	6	42	27
20211	6	42-1	27
20212	15	10	27
20213	15	10-1	27
20214	15	10-2	27
20215	6	42-2	27
20220	6	44	73
20221	3	36	22
20222	2	14	1.5
20223	7	25	1
20224	7	8	8
20225	7	18	5.7
20226	7	23	—
20227	7	11	18
20228	3	35	8
20229	3	38	0.5
20230	7	15	9
20235	6	34	21
20236	6	28	48.6
20237	6	19	60
20253	9	40	1
20253	15	26	1
20254	9	33	1
20254	15	19	1
20255	9	36	0.5
20255	15	22	0.5
20256	9	39-1	4
20256	15	29-1	4
20257	9	39	4
20257	15	29	4
20258	9	39-3	4
20258	15	25-1	4
20259	15	25-2	4
20262	9	39-2	4
20262	15	25	4
20264	15	14	—
20265	15	14-1	—
20266	15	14-2	—
20267	15	28	—
20268	15	28-1	—
20271	9	42	0.5
20272	9	32	1.5
20272	15	17	1.5
20273	9	30	24
20273	15	15	24
20274	9	26	88
20275	9	25	16
20276	9	28	46

INDEX

Parts No.	Page No.	Ref. No.	Weight (g)	Parts No.	Page No.	Ref. No.	Weight (g)	Parts No.	Page No.	Ref. No.	Weight (g)
20279	9	23	34	20370	13	15	43	20452	13	12-2	17
20280	9	22	1.9	20371	11	39	5	20452	15	11-1	17
20281	9	21	7	20372	11	38	40	20453	15	11-2	17
20282	9	15	57	20373	11	34	45	20460	13	12-1	17
20283	9	17	1.2	20374	11	41	17	20460	15	11	17
20284	9	6	6	20375	11	45	8	20461	15	12	8
20286	9	4	2	20376	7	16	7	20462	15	13	2
20287	9	3	8	20376	11	43	7	20480	8	1	36
20290	9	9	1.6	20377	11	31	17	20481	8	5	28
20291	9	29-1	82.3	20378	11	32	5	20483	5	20	29
20292	9	13	9					20484	5	19	41
20293	9	11	1.7	20400	13	21	48	20485	5	18	20
20294	9	29	82.3	20401	13	22	3.9	20486	8	13	136
20295	9	29-2	82.3	20402	13	27	26	20487	8	11	2.5
20296	9	29-3	82.3	20403	13	23	0.5	20488	15	1	3.7
				20405	13	30	6.2	20489	15	5	0.3
20310	10	1	46	20406	13	26	45	20490	8	16	2.2
20311	10	4	7	20407	12	29	8	20491	15	3	5
20311	11	4	7	20408	12	25	56	20492	15	6	2.6
20312	10	6	39	20409	12	21	112	20493	15	7	3.4
20313	10	10	54	20410	5	37	15	20494	8	17	} 10
20314	10	8	3	20411	5	36	14	20495	8	21	
20315	5	28	33	20412	5	35	23	20496	8	19	3
20316	5	29	36	20413	12	26	7	20497	8	24	33
20317	5	27	0.8	20414	12	27	4	20498	8	23	4.5
20318	10	12	45	20415	12	34	14	20498	19	4	4.5
20319	10	19	15	20416	12	37	28	20499	8	22	3.6
20320	10	20	10	20417	12	40	27				
20321	10	22	34	20418	12	41	21	20500	8	27	7.4
20322	10	30	11	20419	12	45	19	20520	14	23	30
20323	10	32	5	20420	12	48	2.3	20526	14	22	439
20324	10	24	5	20421	12	42	5	20530	14	26	5
20325	14	12	0.7	20422	12	5	21	20531	14	27	13
20326	10	18	59	20423	12	4	13	20532	14	28	15
20328	10	11	110.5	20424	12	9	5	20533	14	11	22
20330	10	28	1.5	20425	12	11	16	20534	14	1	53
20331	10	15	2	20426	12	17	47	20535	14	6	49
20332	15	33	5	20427	12	18	45	20538	11	35	0.03
20340	11	1	45	20428	13	34	7	20538	14	32	0.03
20341	11	6	10	20429	13	38	6	20539	14	39	26
20342	11	11	48	20430	13	36	1.3	20540	14	36	5
20343	11	15	44	20432	13	14	20	20542	14	37	0.35
20344	5	30	26	20433	13	37	5	20544	14	35	9.7
20345	5	31	31	20435	5	38	13	20546	14	18	134
20346	11	16	17	20437	3	30	14	20547	14	20	8
20347	11	20	4	20439	13	12	17				
				20440	13	9	8	20600	2	45	2.5
20360	11	9	23	20441	13	11	2	20601	2	45-1	2.5
20361	11	25	7	20442	12	16	92	20651	7	3	3.5
20364	11	27	27	20444	12	33	43	20652	7	6	0.6
20365	11	30	62	20445	12	1	17	20653	7	10	1.3
20366	5	33	22	20447	12	24	72.8	20654	7	2	40
20367	5	34	18					20655	7	1	90
20368	5	32	1.8	20450	13	32	28	20656	7	21	1.4
20369	13	18	65	20451	13	12-3	17	20657	7	22	0.5

INDEX

Parts No.	Page No.	Ref. No.	Weight (g)
20658	2	16	5.6
20659	2	17	1.4
20660	2	22	0.2
20902	16	40	0.05
20903	17	52	0.05
20921	16	39	132
20923	16	33	113
20924	16	34	19
20928	16	43	5
20931	16	24	50
20932	16	22	354
20933	16	23	61.9
20960	17	1	5.5kg
20961	17	53	27
20962	17	53-1	27
20963	17	53-2	27
20964	17	53-3	27
20965	17	54	27
20966	17	54-1	27
20967	17	54-2	27
20968	17	55	27
20969	17	55-1	27
20971	17	40	152
20973	17	2	340
20974	17	36	2
20976	17	34	19
20977	17	30	52
20978	17	25	4
20979	17	38	9
20980	17	22	288
20981	17	17	238
20982	17	19	22
20985	17	5	245
20986	17	9	29
20987	17	42	55
30080	18	31	—
30228	1	19	9
30255	4	4	2.7
30745	14	3	0.4
30748	14	4	0.7
31111	4	7	5
32421	1	25	0.1
32604	6	46	0.9
32612	3	40	0.4
32646	6	9	12
32684	5	21	1
32779	5	4	2.5
32792	12	39	16
32867	13	5	2.8
32899	8	29	2.7
32919	8	26	1
32920	8	9	3.5
32920	12	3	3.5
32960	4	36	1.7

Parts No.	Page No.	Ref. No.	Weight (g)
33013	3	24	14
33024	17	14	0.1
33071	11	28	14
33094	12	31	15
33098	12	15	2
33099	12	19	3.6
33115	13	17	8
33131	3	31	1.1
33141	13	6	12
33251	13	1	32
33252	13	3	2
33574	16	25	4
33575	16	27	2
33581	16	41	3
33588	16	28	1.1
33590	16	26	4
33592	16	35	14
33593	16	37	0.1
33606	11	24	31
33695	17	28	16
33710	17	32	0.5
33711	17	31	0.8
33890	4	2	1.2
33925	16	1	459
33928	16	2	—
33931	16	4	7.7
33932	16	19	15
33933	16	21	87
33934	16	18	64
33935	16	15	11
33936	16	14	58
33937	16	13	5
33938	16	11	7
33939	16	20	12
33941	16	8	43
33942	16	9	—
33949	16	5	4.6
33950	16	7	3
33951	16	6	0.1
33953	16	10	156
34118	11	13	2
34293	9	31	0.06
34293	15	16	0.06
34294	9	7	0.3
34510	1	10	0.8
35149	1	27	210
35150	1	28	6
35296	17	23	17
35297	17	15	5
35300	17	16	1.3
35301	17	13	2.9
35302	17	20	10
35314	17	35	0.1
35720	17	46	16
35721	17	44	1

Parts No.	Page No.	Ref. No.	Weight (g)
35722	17	48	—
35766	17	3	1
35767	17	4	1
37675	14	34	2
37680	14	17	0.7
37901	19	8	—
37902	19	9	—
37903	19	10	—
37907	19	17	—
37911	19	16	—
37912	19	18	—
37913	19	22	—
37916	19	5	—
37919	19	12	—
37922	19	7	—
37923	19	11	—
37932	19	15	—
37939	19	1	—
37943	19	19	—
37945	19	2	—
38077	4	41	3
38221	6	47	0.2
38361	3	17	1
77322	13	25	9
77366	1	22	3
80503	14	5	0.2
85964	19	6	—
93212	6	13	5
93528	4	24	1.8
93550	19	20	0.7
99030	18	17	—
99031	18	18	—
99043	19	13	—
99051	19	21	—
99056	18	1	—
99057	18	2	—
99058	18	3	—
99059	18	4	—
99060	18	5	—
99061	18	8	—
99062	18	11	—
99063	18	14	—
99064	18	19	—
99065	18	21	—
99066	18	22	—
99067	18	24	—
99068	18	25	—
99069	18	26	—
99070	18	29	—
99071	18	30	—

